

# MSP Turbo II™ Vaporizer

## Vaporizer Control Schematic



Application Note VAP-001 (A4)

### System Overview

The MSP Turbo II™ Vaporizer requires three main inputs: compressed air (1), carrier gas (2) and the precursor liquid (3). The vaporizer uses carrier gas to shear the precursor into small droplets for efficient vaporization. The compressed air is required to actuate a pneumatic valve (4) at the top of the vaporizer, which actuates the flow path for the liquid to pass through. The compressed air is not consumed as part of the vaporization process.

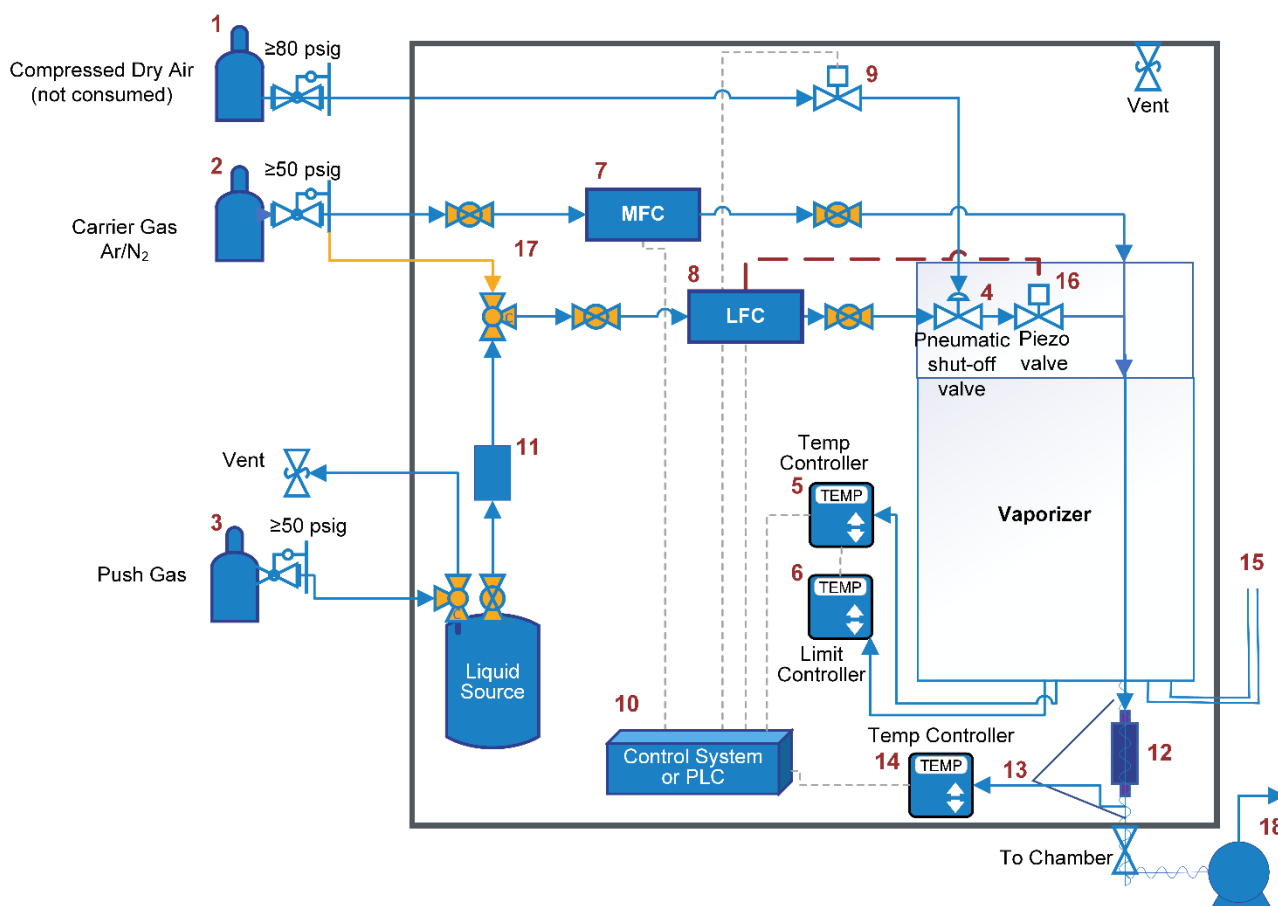

**Figure 1**  
Piping and instrumentation diagram of an example MSP vaporizer system.

## Temperature Regulation

There are two thermocouples in the standard vaporizer; they provide feedback to a user-supplied temperature controller (5) and limit-controller (6). The limit controller shuts off the heater power in an over-temperature event.

## Flow Management and Communication

The Mass Flow Controller (MFC) (7), Liquid Flow Controller (LFC) (8), compressed air actuator (9), temperature limit, and temperature controller communicate with a user-provided control system or Programmable Logic Controller (PLC) (10).

## Liquid and Vapor Filtration

A liquid line filter (11) can be used to remove any particles upstream of the LFC. The MSP™ 2950 LFC has a user-replaceable filter screen at the inlet, but should not be relied on as the main method of filtration. The VPG™ filter (12) at the exit of the vaporizer is commonly used in the semiconductor industry and sometimes for industrial applications where small contaminants could disrupt the process. When wrapped with heat trace, the VPG filter has a high thermal mass and can act as a second source of vaporization in case droplets condense in the line, or simply to further ensure complete vaporization for applications with less room for error.

## Heating Elements

It is important to heat wrap (13) the lines downstream of the vaporizer to prevent condensation. Make sure the thermocouple(s) for the heated line are placed directly on the line and not in contact with the heat wrap, so that the temperature of the line is being controlled rather than the temperature of the heat wrap. The heat wrap will need its own temperature control port or controller (14). The Turbo II™ Vaporizers have internal heaters, which need to be supplied with AC Power (15). The power requirements vary by vaporizer and this information can be found in the vaporizer's spec sheet.

## Advanced Liquid Control

For Performance Enhanced (PE) vaporizers, the liquid control is determined by a piezo valve (16) located on the atomizer of the vaporizer; this can be controlled using an MSP 2950 LFC or another piezo driver. Controlling the liquid at the point of atomization greatly reduces dead volume. The MSP 2950 LFC can operate via EtherCAT, RS-485, and analog signals.

## Preventative Maintenance

For optimal process hygiene, incorporating a purge gas system (17) is crucial, particularly since many vaporization chemistries react with ambient air, leading to clogs. To counteract this, a dedicated pumping system (18) should be employed for effective purging and pumping, ensuring the removal of reactive materials and maintaining a clean liquid line.

---

# Vaporizer Control Sequencing with Vacuum

## Safety Considerations

1. Evacuate all ambient air from the system before introducing chemistry.
2. Ensure liquid lines are evacuated before opening lines.
3. Always run carrier gas before flowing liquid.

## Evacuation

1. Set vaporizer to desired temperature; wait for stabilization.
2. Close liquid supply valve above LFC.
3. Turn on carrier gas.
4. Open vaporizer's pneumatic shut-off valve.
5. Set LFC for evacuation flow.
6. Allow vacuum to evacuate liquid line and LFC.
7. Purge with inert gas for 30 to 60 seconds.
8. Repeat steps 6 and 7 for a total of three purge/evacuation cycles.
9. Allow vacuum to evacuate liquid line and LFC until steady-state pressure is achieved, or run vacuum overnight or for 24 hours if no LFC pressure readings are available.

## Priming

1. Follow evacuation protocol.
2. Close the piezo valve.
3. Close the pneumatic shut-off valve.
4. Open upstream liquid supply valve.
5. Allow liquid to fill the system under vacuum until flow stabilizes.

## Process Control

1. Set vaporizer to desired temperature; wait for stabilization.
2. Turn on carrier gas.
3. Open pneumatic valve.
4. Wait for pressure stabilization (2–3 seconds).
5. Set LFC to desired flow rate.

## Shut-off

1. Set LFC to zero.
2. Close pneumatic valve.
3. Turn off carrier gas.
4. Switch off temperature controller unless process continues shortly after.

### NOTICE

Please remember to evacuate lines before opening them up to ambient air!

---

# Vaporizer Control Sequencing without Vacuum

## Safety Considerations

1. Purge all ambient air from the system before priming.
2. Ensure any chemistry within liquid lines are evacuated before opening lines.
3. If possible, use a separate vacuum system to pump down the lines.
4. Always run carrier gas before flowing liquid.

## Evacuation

1. Set vaporizer to desired temperature; wait for stabilization.
2. Close liquid supply valve above LFC.
3. Turn on carrier gas.
4. Open vaporizer's pneumatic shut-off valve.
5. Set LFC for evacuation flow rate.
6. Run purge gas through the liquid supply line and LFC until ambient air or chemistry has been removed from lines.
  - Appropriate purge times will vary by chemistry.
7. Close the pneumatic shut-off valve.
8. Set LFC to zero.
9. Close purge gas supply valve.

## Priming

1. Follow evacuation protocol.
2. Turn on carrier gas.
3. Open vaporizer's pneumatic shut-off valve.
4. Set LFC piezo voltage to 100V.
5. Open upstream liquid supply valve.
6. Scale down the piezo voltage until a slight flow rate is observed.
7. Allow time for liquid to fill the lines.
8. Proceed with "Shut-off" protocol.

## Process Control

1. Set vaporizer to desired temperature; wait for stabilization.
2. Turn on carrier gas.
3. Open pneumatic valve.
4. Wait for pressure stabilization (2–3 seconds).
5. Set LFC to desired flow rate.

## Shut-off

1. Set LFC to zero.
2. Close pneumatic valve.
3. Turn off carrier gas.
4. Switch off temperature controller unless process continues shortly after.

### NOTICE

Please remember to evacuate lines before opening them up to ambient air!

## Disclaimer

This document provides general guidelines for vaporizer operation. It is the responsibility of the user to ensure proper integration of these guidelines into their specific operational context, which will require process integration expertise. Our company is not liable for any outcomes resulting from the application of these guidelines, including adherence without customization to your processes. Should issues arise, cease operation and consult our technical support. Qualified personnel should conduct all process operations.



MSP – Visit our website [www.tsi.com/msp](http://www.tsi.com/msp) for more information.

5910 Rice Creek Parkway, Suite 300  
Shoreview, Minnesota  
55126, U.S.A.  
Tel: 651.287.8100