

MODEL 8630 PRESSURA™ ROOM PRESSURE MONITOR

INSTALLATION INSTRUCTIONS

WARNING: The Model 8630 Room Pressure Monitor must be wired to 24 VAC only. Wiring the unit to 110 VAC will cause serious damage to the unit and void the warranty.

The pressure sensor must be mounted through the wall between the controlled space (isolation room) and referenced space (ante room / hallway).

These installation instructions guide the installer through the installation of the TSI Model 8630 PresSura™ Room Pressure Monitor. Please read these instructions thoroughly before beginning installation.



This product is classified by Underwriters Laboratories, Inc.® for use in through-penetration firestop systems. See UL fire resistance directory.

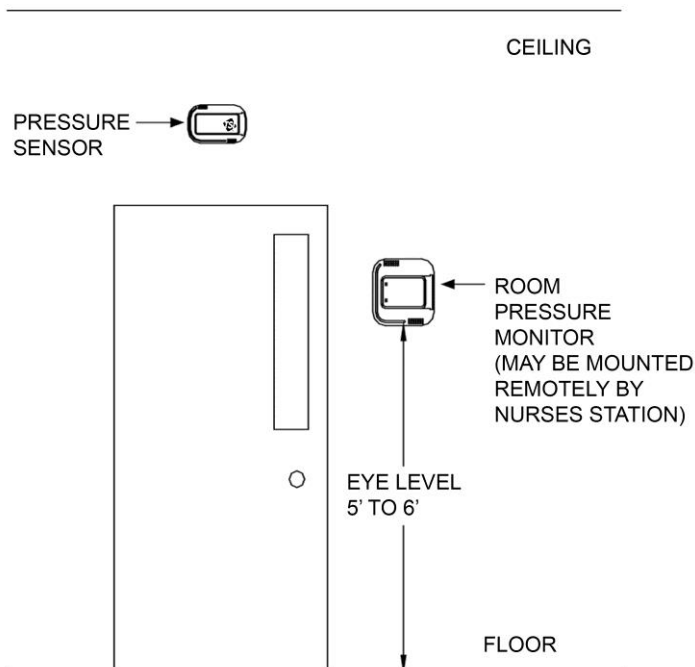

Figure 1: Typical Installation

Component List

Part Number	Qty	Description
800243	1	Pressure sensor
800248	1	Sensor cable
800244	1	8630-SM Room pressure monitor
	<i>or</i>	
800245	1	8630-PM Room pressure monitor
800420	1	Transformer
800414	1	Transformer cable
1901057	2	Intumescent ring
2923020	1	Fire sealant



Pressure Sensor Installation

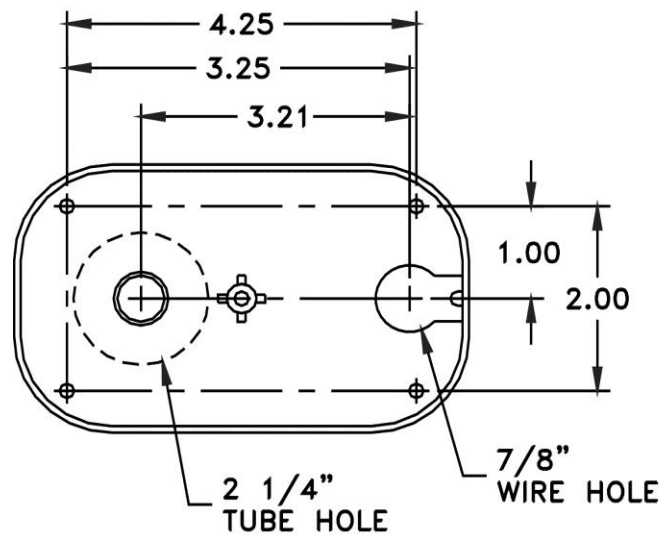
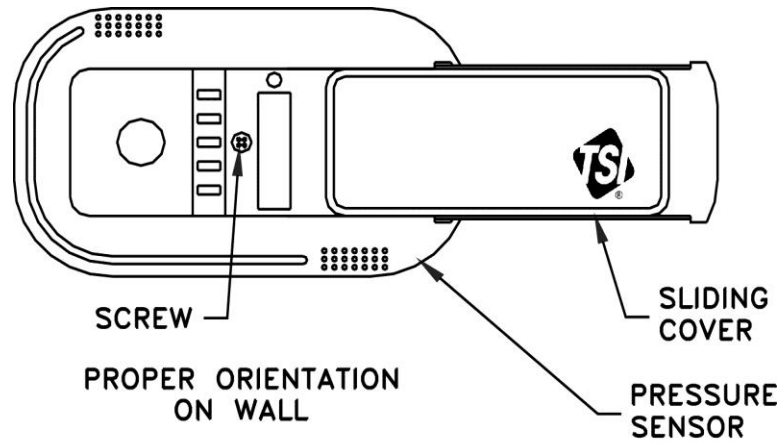

PRESSURE SENSOR BASE

Figure 2: Pressure Sensor Orientation and Mounting Template

WARNING: 800243 pressure sensor **must** be mounted through the wall between the controlled space (isolation room) and referenced space (hallway), exactly as shown in Figure 2 and 3.

1. Determine pressure sensor location (Figures 1, 2 and 3). Pressure sensor typically mounts in the reference space, and the dummy housing mounts in the isolation room.

Note: Pressure sensor is not symmetrical. If sensor is to be centered over hallway door, measure one inch to the left of center for 2 1/4" hole. Dummy sensor will be 2" off center on other side of wall.

2. The pressure sensor must be orientated on the wall as shown in Figure 2. Looking at the mounted sensor, sensor hole is on the left (2 1/4") and wire hole is on the right.
3. Drill a 2 1/4-inch hole through each side of the wall to accept the sensor tube.
4. Drill a 7/8-inch hole on the side of the wall that the pressure sensor will be mounted. This hole is for the six-conductor sensor cable. Refer to Figure 2 for a hole mounting pattern.
5. Slide sensor cover to right and remove screw that holds the sensor base to the pressure sensor (Figure 2). Remove pressure sensor and store in a safe place.

6. From the side of the wall the sensor will be mounted, slide the sensor tube through the wall. Mark the tube where it is flush with wall. Remove sensor tube and cut tube 1/8 inch shorter than flush marking.
- Note: If 12" sensor tube needs to be extended, use same size or larger diameter tube. Drill out 1/2" sensor hole in dummy case to match ID of tube extension.*
7. From the side of the wall the sensor will be mounted, slide the sensor tube through the wall. Slide the dummy base over the end of the tube. Screw the pressure sensor base and dummy base to the wall (Figure 3).
8. Wire the pressure sensor per Figure 7. Run sensor cable to the room pressure monitor 4" x 4" electrical rough-in box.
9. Insert fire protection sealant (provided) into 7/8" wire hole to seal.
10. Install and screw the pressure sensor and dummy cover onto the bases. Slide covers to the left to hide the sensor. Finished installation should look as shown in Figure 4.

WARNING: Do **not** touch the sensor element in the pressure sensor. Do **not** run wires through the air passage. Doing so will damage the sensing element.

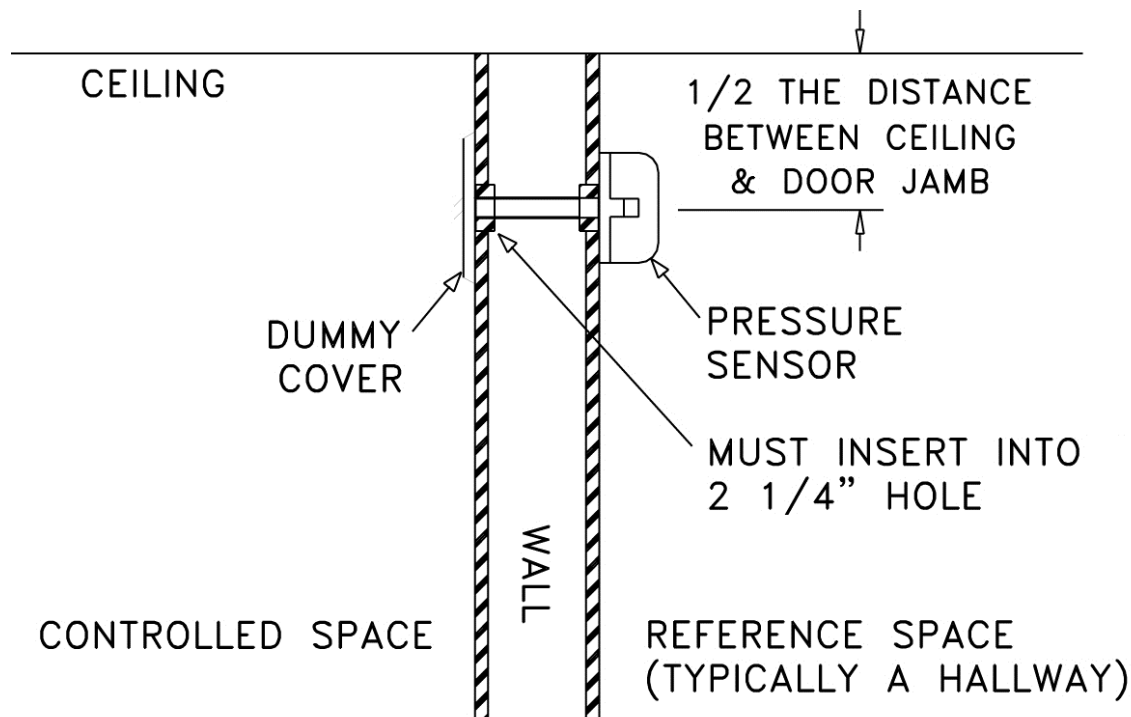

Figure 3: Cutaway View of Mounted Pressure Sensor

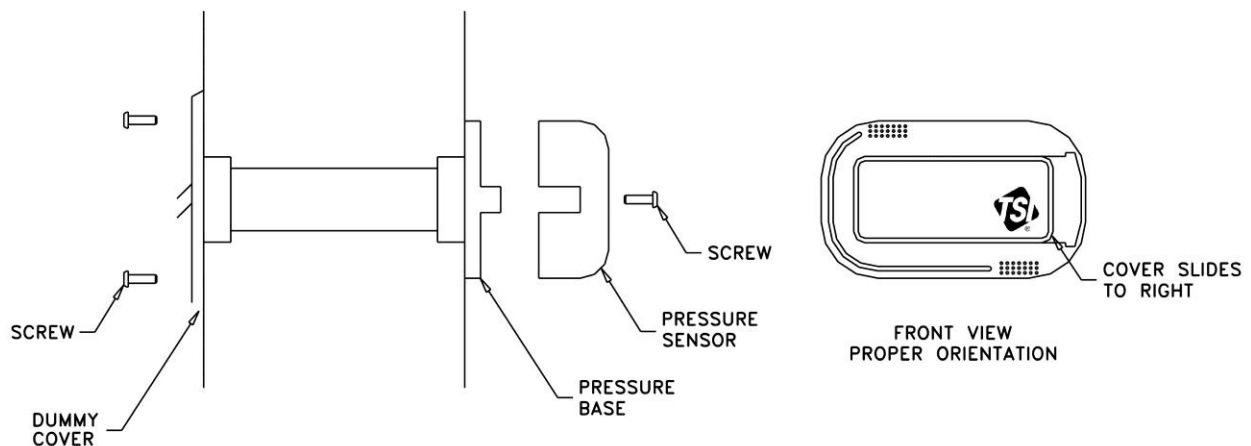

Figure 4: Pressure Sensor Mounting

Transformer Installation

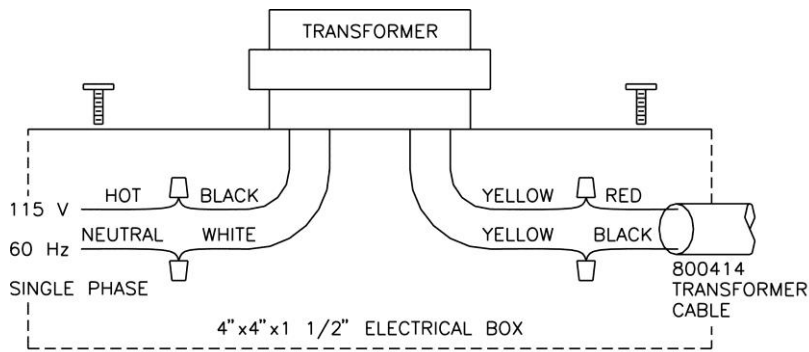

Figure 5: Transformer Installation

WARNING

Make sure no power is applied until all wiring is complete.

Follow all applicable electrical codes, and have qualified personnel install the transformer.

Note: Each system must be installed with supplied transformer. If TSI transformer is discarded and a central transformer is installed, a separate isolation transformer must be installed in line between the TSI system and central transformer.

1. Mount a standard 4" x 4" x 1 1/2" electrical box at a convenient location within 20 feet of pressure monitor.
2. Run 115 Volt, single phase, 60 hertz line voltage (115 VAC) to electrical box. Follow all applicable electrical codes.
3. Connect 115 VAC line voltage **HOT** wire to **BLACK** wire on transformer and **NEUTRAL** wire to **WHITE** wire on transformer (Figure 5).
4. Connect the RED wire on 800414 transformer cable to either of the **YELLOW** wires on the transformer and the **BLACK** wire to the remaining **YELLOW** wire.
5. Screw the transformer to the electrical box.
6. Run transformer cable from the transformer electrical box to the pressure monitor. Have at least 8 inches of cable coming out of the pressure monitor rough in electrical box before trimming cable to length.

Pressure Monitor Installation

Pressure Monitor Rough-in

1. Select the mounting location of the pressure monitor. The construction plans normally show the mounting location. If no location is specified, then the unit is typically installed as shown in Figure 1. Alternate mounting locations are nurse's station, other staff areas, etc.
2. Install a standard double gang electrical box (4" x 4").
3. Slide the pressure monitor cover to the right and remove three screws holding the electronics to the base (Figure 6). Remove base.
4. Install the base to the 4" x 4" electrical box. The base's "THIS SIDE UP" arrow must be pointing towards the ceiling.

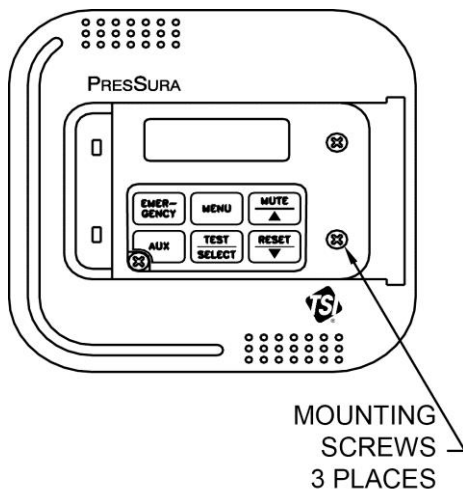

Note: Two screws are hidden behind the cover when full open. The cover will slide to the right approximately 2 inches until a stop is hit. Pull cover to completely remove from electronics and expose the screws.

Figure 6: Pressure Monitor Mounting

Pressure Monitor Wiring

WARNING: Do **not** connect more than 24 VAC to any terminal.

Do **not** apply voltage to the RS-485 output, analog output, or control output. Severe damage may occur to the unit if voltage is applied.

1. Remove the connectors from the back of the pressure monitor.
2. Refer to the wiring diagram (Figure 7) for proper wiring installation.
3. If additional options need to be wired, refer to building prints for proper wiring diagram.
4. Plug the connectors back into the pressure monitor.
5. Carefully push the wires into the electrical box and mount the pressure monitor. Install three screws to hold pressure monitor firmly to base. Install cover and slide left to hide display.

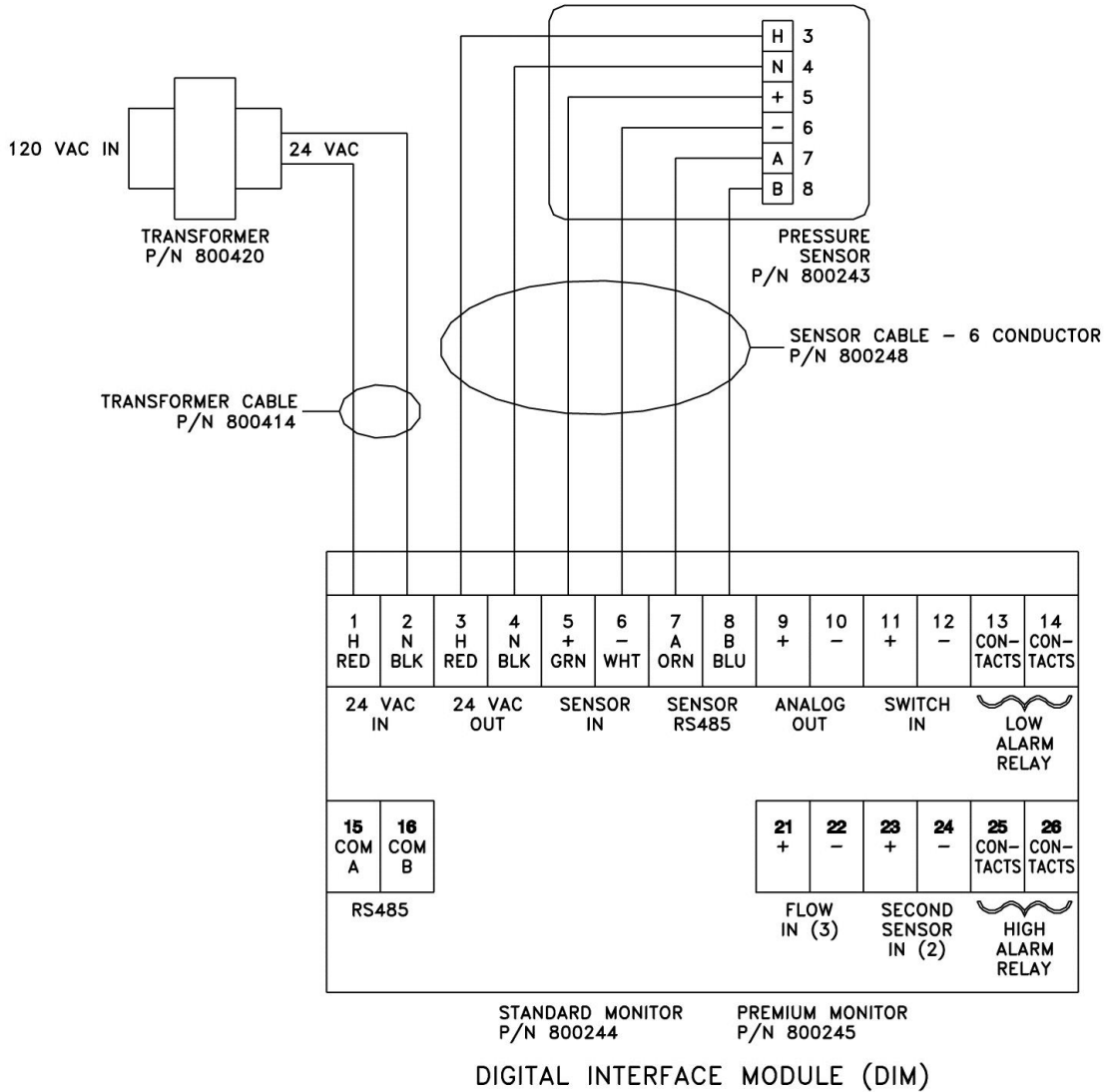

NOTE: PINS 15, 16, 21-26 FUNCTION ON PREMIUM MODEL ONLY

WARNING: Monitor must be wired exactly as wire diagram shows. Making modifications to the wiring may severely damage the unit.

Figure 7: Wiring Diagram

If you need assistance installing the system, call TSI at (800) 874-2811.



UNDERSTANDING, ACCELERATED

TSI Incorporated – Visit our website www.tsi.com for more information.

USA	Tel: +1 800 874 2811	India	Tel: +91 80 67877200
UK	Tel: +44 149 4 459200	China	Tel: +86 10 8219 7688
France	Tel: +33 1 41 19 21 99	Singapore	Tel: +65 6595 6388
Germany	Tel: +49 241 523030		

