

# POSITIVE / NEGATIVE CHANGEOVER SWITCH

## INSTALLATION INSTRUCTIONS

### Installing with the Model 8670 Room Pressure Controller

The purpose of these instructions is to guide the installer through the installation of the optional TSI Model 8694 Changeover Switch to the Model 8670 Room Pressure Controller. The complete Model 8670 Room Pressure Controller installation is covered in the *Model 8670 Room Pressure Controller Installation Instructions*.

The changeover switch must be wired per the figure below. Wire should be 24 AWG or larger (not supplied by TSI). Any modification to the wiring may damage the alarm and room pressure device.

The Model 8694 has the following electrical characteristics:

| Key Position | Output         |
|--------------|----------------|
| Negative     | Contact open   |
| Positive     | Contact closed |

This concludes installation of the changeover switch. If you need assistance installing the controller see the *Model 8670 Room Pressure Controller Installation Instructions*. If you need further assistance contact your local representative or TSI at 1-800-874-2811.

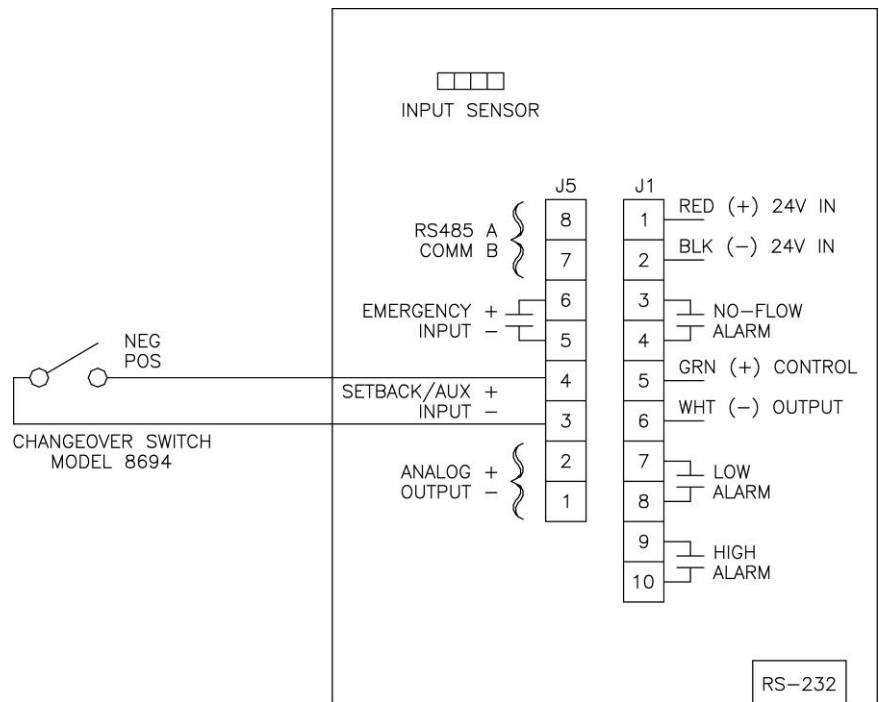

PRESSURE CONTROLLER  
P/N 800242



# POSITIVE / NEGATIVE CHANGEOVER SWITCH

## INSTALLATION INSTRUCTIONS

### Installing with the Model 8670 Room Pressure Controller

The purpose of these instructions is to guide the installer through the installation of the optional TSI Model 8694 Changeover Switch to the Model 8620 Room Pressure Monitor. The complete Model 8620 Room Pressure Monitor installation is covered in the *Model 8620 Room Pressure Monitor Installation Instructions*.

The changeover switch must be wired per the figure below. Wire should be 24 AWG or larger (not supplied by TSI). Any modification to the wiring may damage the alarm and room pressure device.

The Model 8694 has the following electrical characteristics:

|              |                |
|--------------|----------------|
| Key Position | Output         |
| Negative     | Contact open   |
| Positive     | Contact closed |

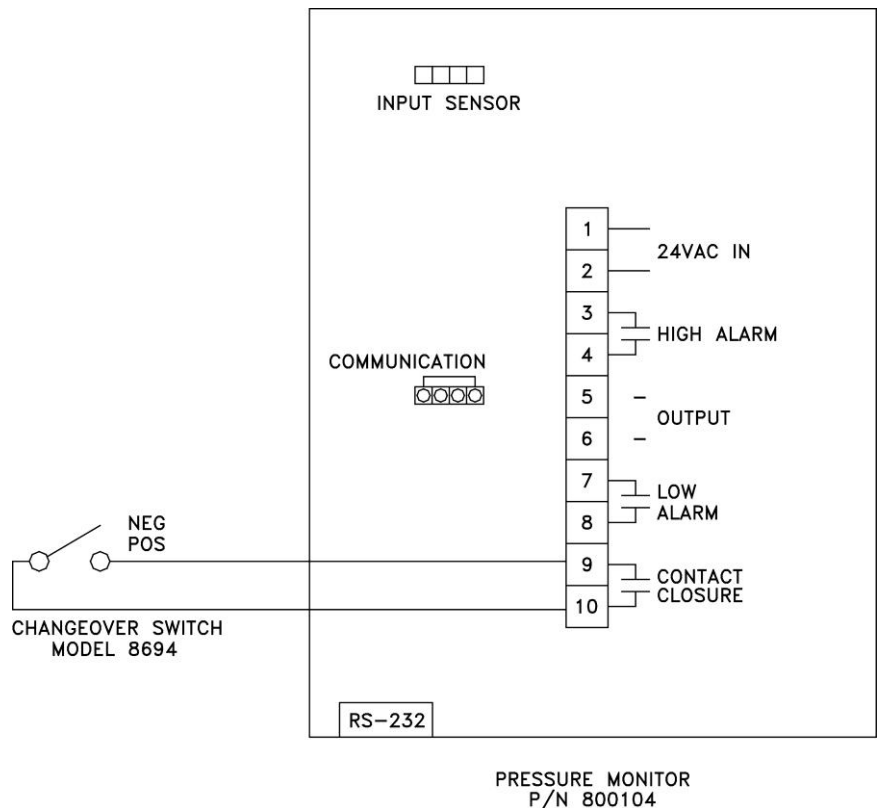

This concludes installation of the changeover switch. If you need assistance installing the monitor see the *Model 8620 Room Pressure Monitor Installation Instructions*. If you need further assistance contact your local representative or TSI at 1-800-874-2811.



UNDERSTANDING, ACCELERATED

TSI Incorporated – Visit our website [www.tsi.com](http://www.tsi.com) for more information.

|         |                       |           |                       |
|---------|-----------------------|-----------|-----------------------|
| USA     | Tel: +1 800 874 2811  | India     | Tel: +91 80 67877200  |
| UK      | Tel: +44 149 4 459200 | China     | Tel: +86 10 8251 6588 |
| France  | Tel: +33 491 11 87 64 | Singapore | Tel: +65 6595 6388    |
| Germany | Tel: +49 241 523030   |           |                       |