

# Interfacing TSI<sup>®</sup> Transducers with Data Acquisition Boards

Application Note TI-123

When interfacing TSI<sup>®</sup> Transducers with data acquisition boards many problems can be encountered. In this application note, we attempt to explain the requirements and help the user to set up their system.

When interfacing the transducers to a data acquisition board fully differential input works the best. This means that each channel has its own (+) input and (-) input. The (-) inputs are not grounded, but are separate from ground.

## Single-Ended Inputs

Single-ended input cards have only a (+) input. All the (-) inputs are connected to ground. These single-ended input cards have only one advantage: they give you more input channels for less money. This is because there is only one electronic switch for each channel (the (+) input).

Unless all of the sensors you attach to your data acquisition card are current loop powered, it is difficult to wire a single-ended data acquisition card without introducing zero errors into the measurement. (**NOTE:** TSI air velocity transducers cannot be loop powered because they require too much current.) Figure 1 shows why the zero error occurs.

---

TSI is a registered trademark of TSI Incorporated. TSI logo is a trademark of TSI Incorporated.



GROUND LOOP CAUSES ZERO ERROR

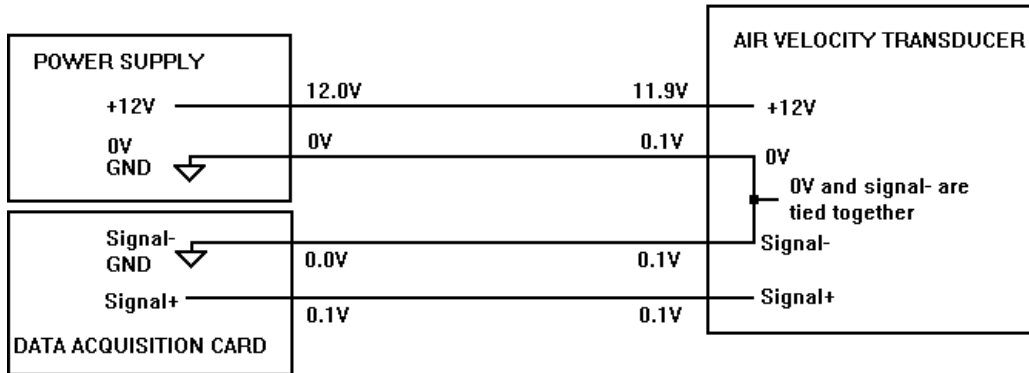

Figure 1: Ground Loop Causes Zero Error

Since the power supply and the data acquisition card are both grounded, there is a ground loop which causes an error in the zero reading that the data acquisition card measures. This error cannot be removed by re-zeroing the transducer, because the error will change when the power requirements of the air velocity transducer change (when the wind blows). To solve this problem, unground the power supply as in Figure 2.

UNGROUNDING POWER SUPPLY ELIMINATES GROUND LOOP ERROR

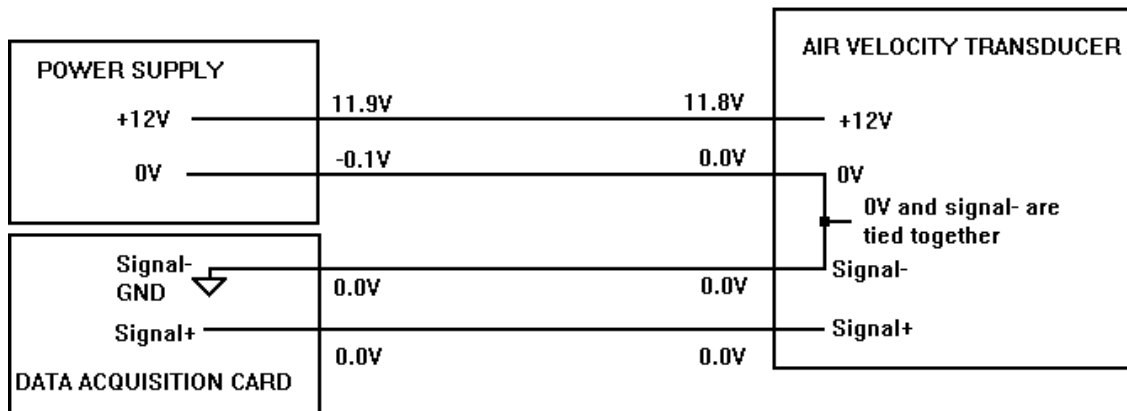

Figure 2: Ungrounding the Power Supply

This will solve the problem until we add another transducer, then another ground loop error is created. See Figure 3. This ground loop error was created because the signal (-) wires of the two transducers are connected together at the data acquisition card. The power supply currents of the two transducers are flowing through the signal (-) wires, creating errors.

WITH MORE THAN ONE TRANSDUCER, THE GROUND LOOP PROBLEM RETURNS

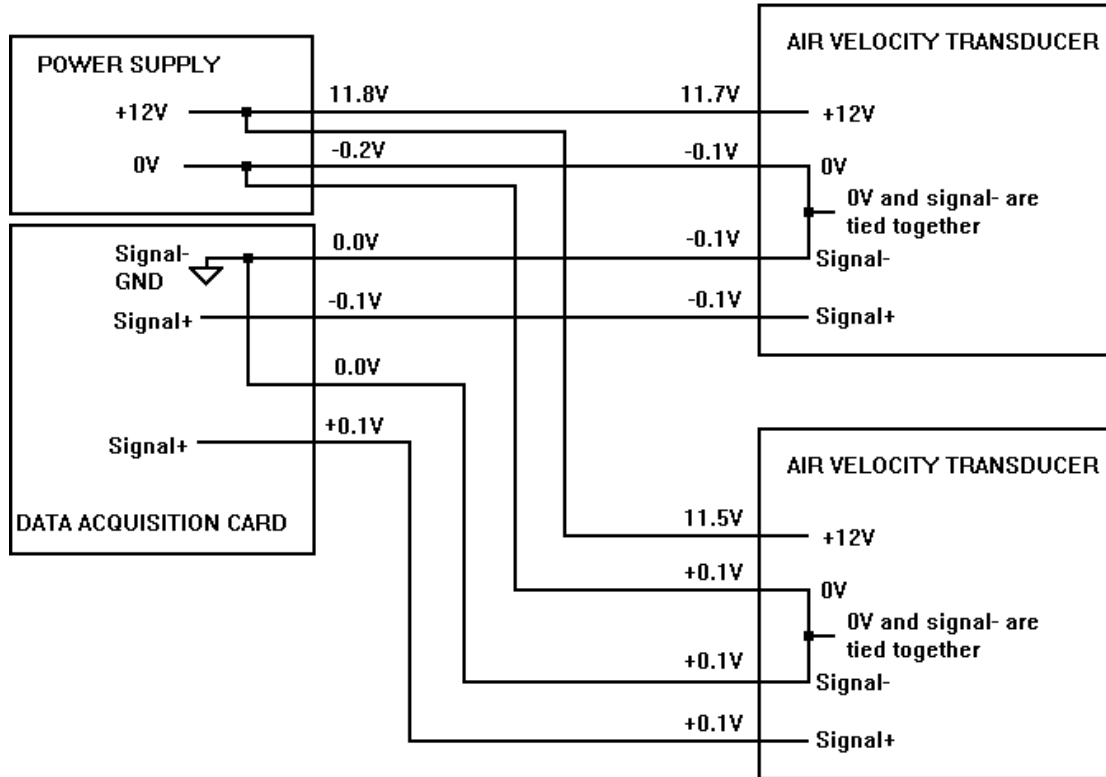

Figure 3: Ground Loop Errors With More Than One Transducer

This problem can be solved by using two isolated power supplies, see Figure 4.

USING ONE POWER SUPPLY FOR EACH TRANSDUCER, IF THE ONLY GND CONNECTION IS AT THE DATA ACQUISITION CARD, A SINGLE-ENDED DATA ACQUISITION CARD CAN BE MADE TO WORK BUT.....

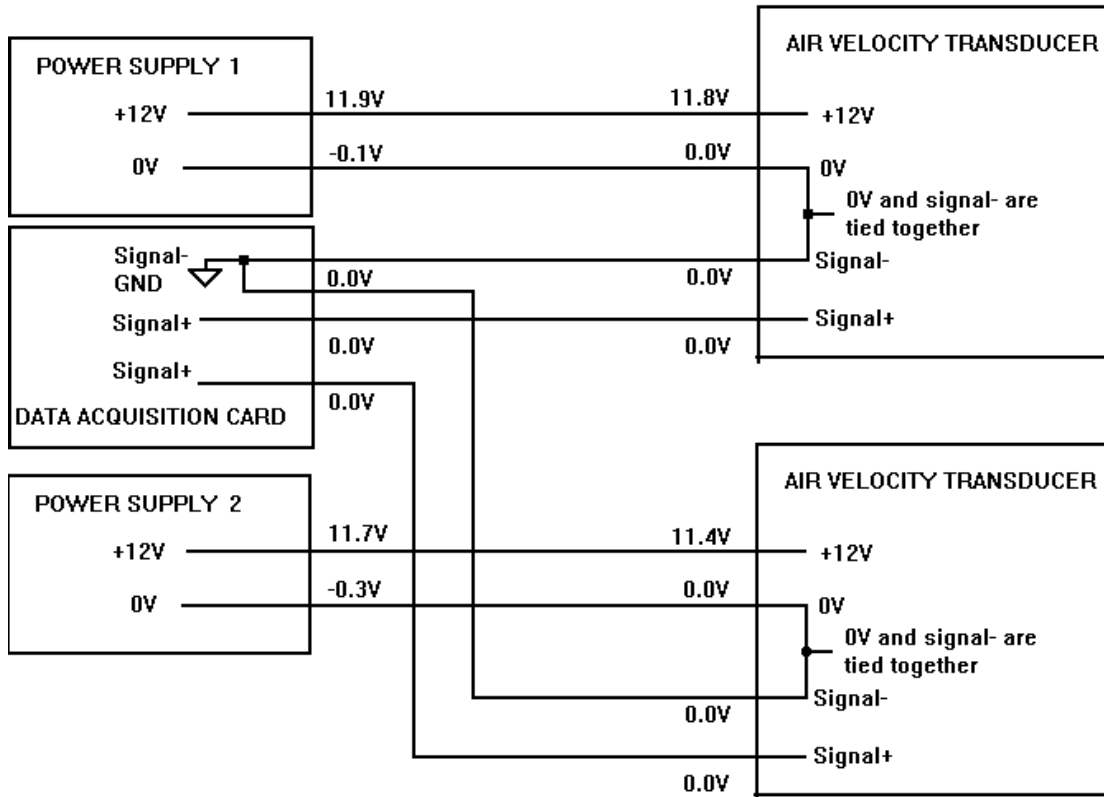

Figure 4: Two Power Supplies, Two Transducers

However, the case of the TSI Air Velocity transducer is made of metal and is also connected to the air velocity 0V and signal (-) terminals. In order for the solution in Figure 4 to work, the only ground connection must be at the data acquisition card. This means that the cases of both air velocity transducers must remain also disconnected from ground. If both cases contact earth ground, the ground loop will be completed through the cases, and the problem will return. If either case contacts an earth ground, any current flowing in the building's grounding system will also cause zero offset errors, and the problem will return.

As can be seen, this is very time consuming and expensive. The better solution is to use fully differential inputs.

### Fully Differential Inputs

Using a fully differential data acquisition card is the best solution to this problem. Figure 5 shows the schematic of this arrangement.

THE BEST WAY: FULLY DIFFERENTIAL INPUTS

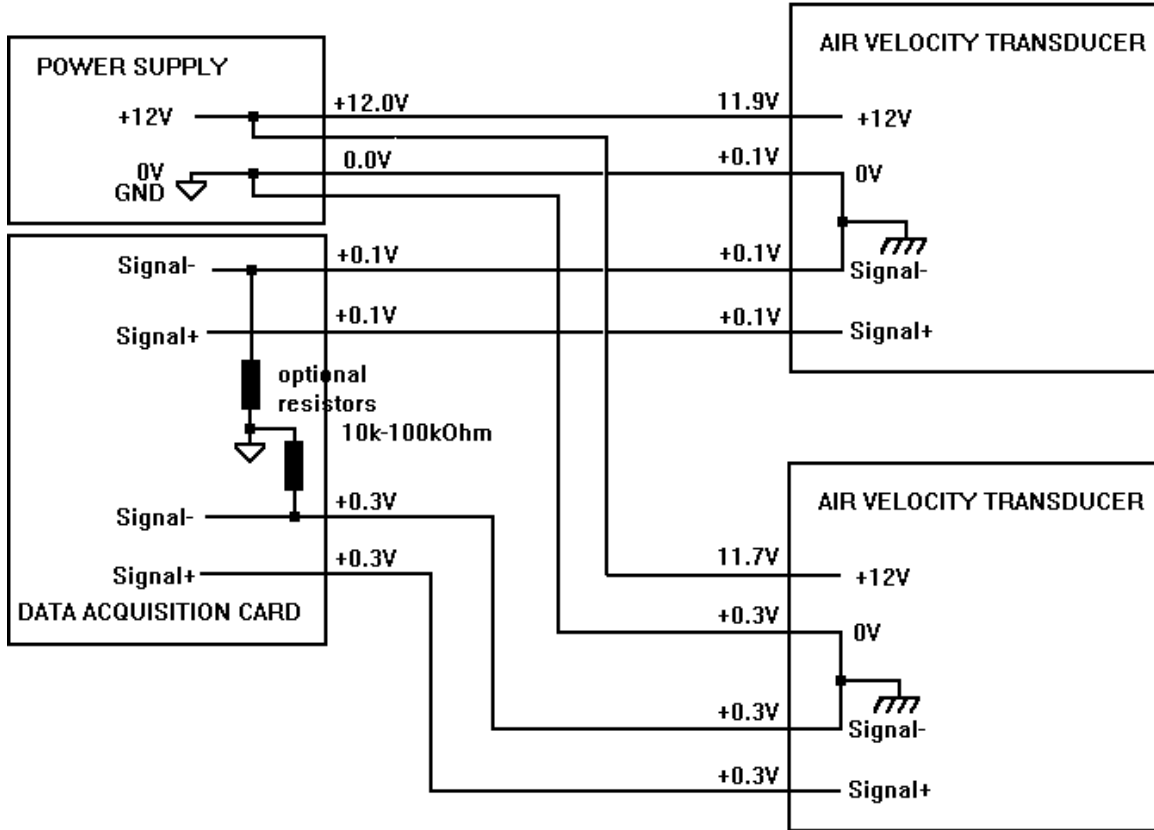

Figure 5: Fully Differential Inputs (2 Transducers)

Looking at the schematic, it can be seen that there are still error voltages at the inputs to the data acquisition card, but since the errors are equal for the Signal (+) and Signal (-), the differential input card will ignore them.

There are also two optional resistors connected from the Signal (-) terminals to ground on the data acquisition card. These resistors do NOT effectively complete a ground loop. Their purpose is to keep the air velocity transducer signals from floating with respect to the data acquisition card. As long as the power supply is connected to ground or the air velocity transducers are connected to ground, the resistors will not be needed.

If the air velocity transducers are not screwed into anything metal, and the ground connection at the power supply is unreliable or broken, then that would allow the Signal (+) and the Signal (-) terminals to float. This could cause the common mode input voltage range for the data acquisition card to be exceeded, causing unreliable readings. If resistors of 10k ohm are connected from Signal (-) to ground at the data acquisition card, they will prevent the Signal (+) and Signal (-) inputs from floating.

**For 4-20 mA outputs**

A fully differential input data acquisition card can also be used if the air velocity transducer is set for 4-20 mA outputs. The 100 Ohm resistors turn the 4-20 mA input into 0.4 to 2.0 Volts. In that case, the hookup is as in Figure 6.

**4-20mA SIGNALS WITH FULLY DIFFERENTIAL DATA ACQUISITION CARD**  
**100 Ohm RESISTORS TURN 4-20mA INTO 0.4-2.0 VOLTS.**

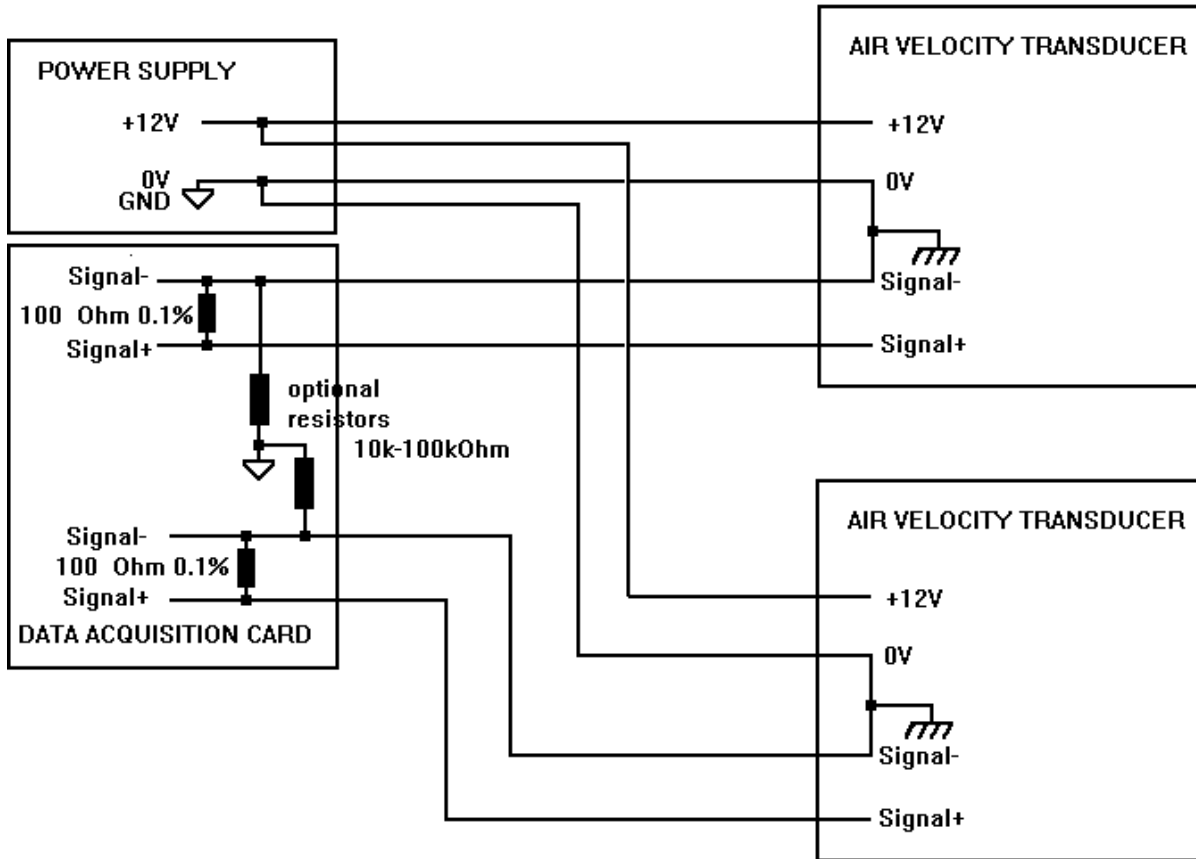

**Figure 6: Single-Ended Data Acquisition Card (4-20 mA)**

It is also possible to use a single-ended input data acquisition card using 4-20 mA signals and not have errors due to ground loops. See Figure 7.

4-20mA SIGNALS WITH SINGLE-ENDED DATA ACQUISITION CARD.  
 100 Ohm RESISTORS TURN 4-20mA INTO 0.4-2.0 VOLTS.

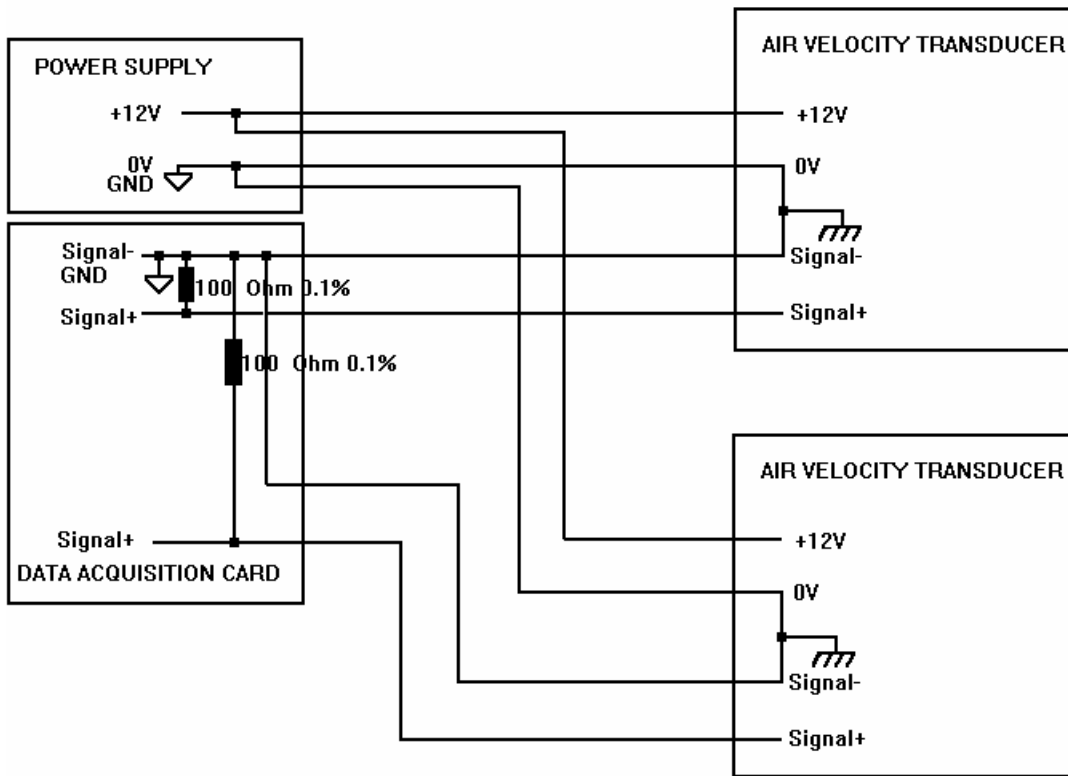

Figure 7: Fully Differential Data Acquisition Card (4-20 mA)

This is one way to use a single-ended input data acquisition card and not have zero problems with the transducers. Why does this work? The transducers monitor the current flowing through the 100 Ohm resistors and correct it to be what it is suppose to be, regardless of any ground loops. This correction is good, but not perfect. The zero errors should be unnoticeable, however.

**TSI Incorporated** – 500 Cardigan Road, Shoreview, MN 55126 U.S.A

USA	Tel: +1 800 874 2811	E-mail: <a href="mailto:answers@tsi.com">answers@tsi.com</a>	Website: <a href="http://www.tsi.com">www.tsi.com</a>
UK	Tel: +44 149 4 459200	E-mail: <a href="mailto:tsiuk@tsi.com">tsiuk@tsi.com</a>	Website: <a href="http://www.tsiinc.co.uk">www.tsiinc.co.uk</a>
France	Tel: +33 491 11 87 64	E-mail: <a href="mailto:tsifrance@tsi.com">tsifrance@tsi.com</a>	Website: <a href="http://www.tsiinc.fr">www.tsiinc.fr</a>
Germany	Tel: +49 241 523030	E-mail: <a href="mailto:tsigmbh@tsi.com">tsigmbh@tsi.com</a>	Website: <a href="http://www.tsiinc.de">www.tsiinc.de</a>
India	Tel: +91 80 41132470	E-mail: <a href="mailto:tsi-india@tsi.com">tsi-india@tsi.com</a>	
China	Tel: +86 10 8260 1595	E-mail: <a href="mailto:tsibeijing@tsi.com">tsibeijing@tsi.com</a>	



Contact your local TSI Distributor or visit our website [www.tsi.com](http://www.tsi.com) for more detailed specifications.