

MODEL 8635 SUREFLOW

ROOM PRESSURE MONITOR

INSTALLATION INSTRUCTIONS

WARNING: The Model 8635 Room Pressure Monitor must be wired to 24 VAC only. Wiring the unit to 110 VAC will cause serious damage to the unit and void the warranty.

The pressure sensor must be mounted through the wall between the controlled space (laboratory) and referenced space (hallway).

These installation instructions guide the installer through the installation of the TSI Model 8635 SUREFLOW Room Pressure Monitor. Please read these instructions thoroughly before beginning installation.



This product is classified by Underwriters Laboratories, Inc. for use in through-penetration firestop systems. See UL fire resistance directory.

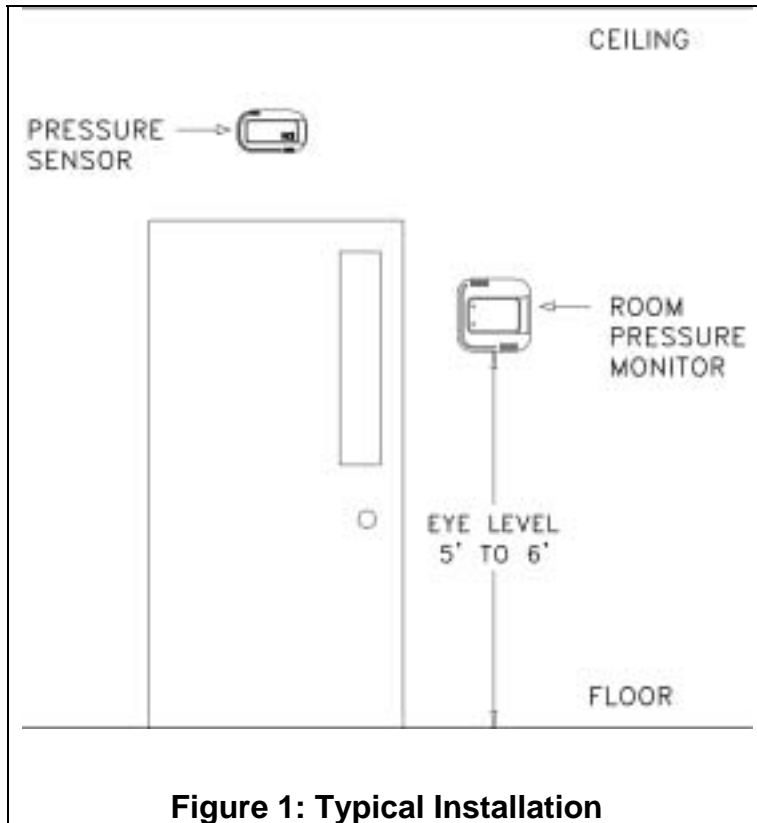

COMPONENT LIST

Part Number	Qty	Description
800326	1	Pressure sensor
800248	1	Sensor cable
800222	1	Room pressure monitor
800420	1	Transformer
800414	1	Transformer cable
1901057	2	Intumescent ring
2923020	1	Fire sealant

PRESSURE SENSOR INSTALLATION

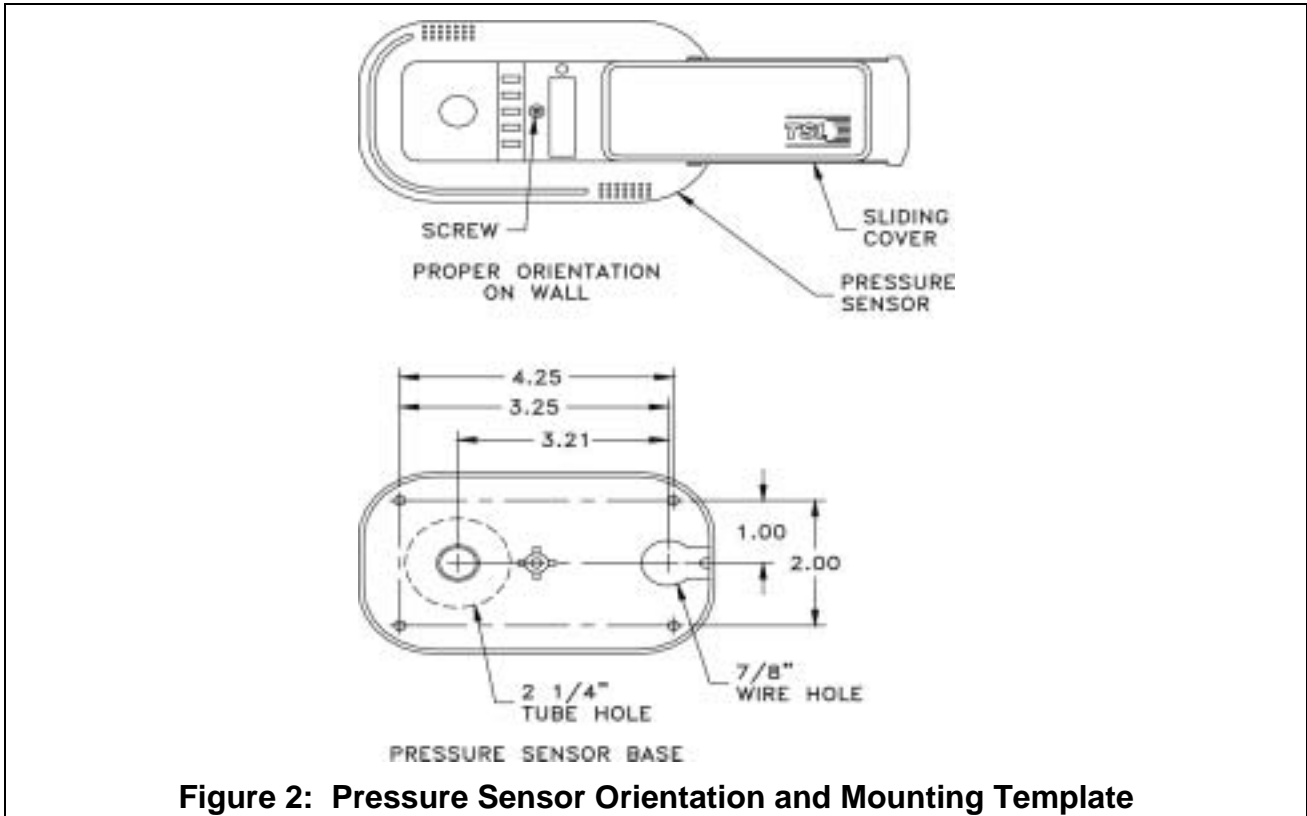

Figure 2: Pressure Sensor Orientation and Mounting Template

WARNING: 800326 pressure sensor must be mounted through the wall between the controlled space (laboratory) and referenced space (hallway), exactly as shown in Figure 2 and 3.

- Determine pressure sensor location (Figures 1, 2 and 3). Pressure sensor typically mounts in the reference space, and the dummy housing mounts in the laboratory.

NOTE: Pressure sensor is not symmetrical. If sensor is to be centered over hallway door, measure one inch to the left of center for 2 1/4" hole. Dummy sensor will be 2" off center on other side of wall.

- The pressure sensor must be orientated on the wall as shown in Figure 2. Looking at the mounted sensor, sensor hole is on the left (2 1/4") and wire hole is on the right.
- Drill a 2-1/4 inch hole through each side of the wall to accept the sensor tube.
- Drill a 7/8 inch hole on the side of the wall that the pressure sensor will be mounted. This hole is for the six-conductor sensor cable. Refer to Figure 2 for a hole mounting pattern.
- Slide sensor cover to right and remove screw that holds the sensor base to the pressure sensor (Figure 2). Remove pressure sensor and store in a safe place.

- From the side of the wall the sensor will be mounted, slide the sensor tube through the wall. Mark the tube where it is flush with wall. Remove sensor tube and cut tube 1/8 inch shorter than flush marking.

NOTE: If 12" sensor tube is not long enough add a 1" to 2" adapter and extend with 2" OD tube. The base of the dummy housing will need to be drilled out to accommodate 2" tube. Do not extend sensor tube with 1" tubing.

- From the side of the wall the sensor will be mounted, slide the sensor tube through the wall. Slide the dummy base over the end of the tube. Screw the pressure sensor base and dummy base to the wall (Figure 3).
- Wire the pressure sensor per Figure 7. Run sensor cable to the room pressure monitor 4" x 4" electrical rough-in box.
- Insert fire protection sealant (provided) into 7/8" wire hole to seal.
- Install and screw the pressure sensor and dummy cover onto the bases. Slide covers to the left to hide the sensor. Finished installation should look as shown in Figure 4.

Warning: Do not touch the sensor element in the pressure sensor. Do not run wires through the air passage. Doing so will damage the sensing element.

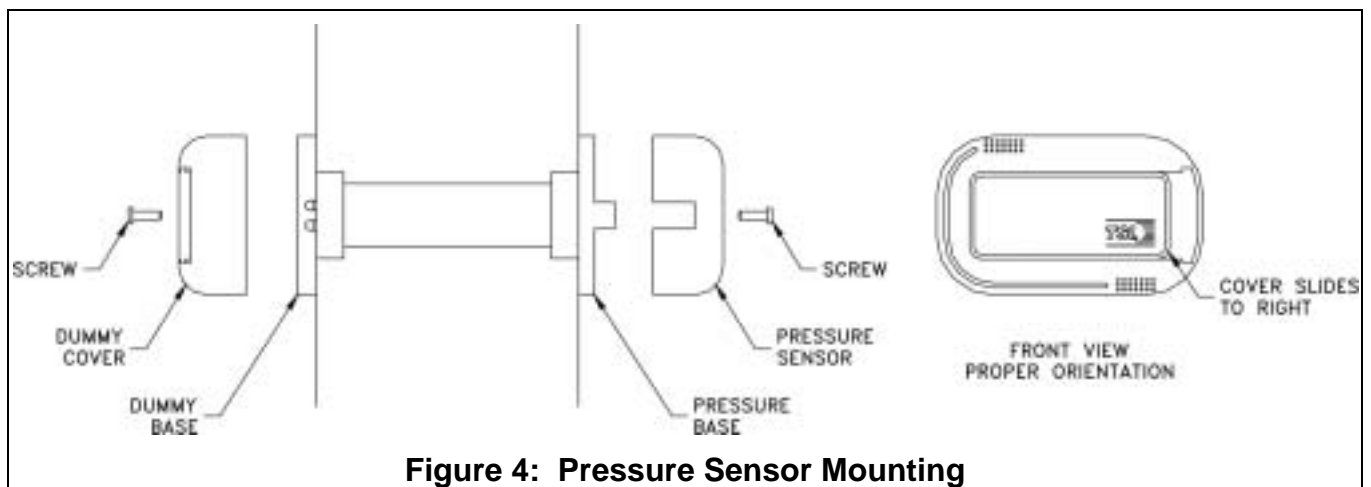
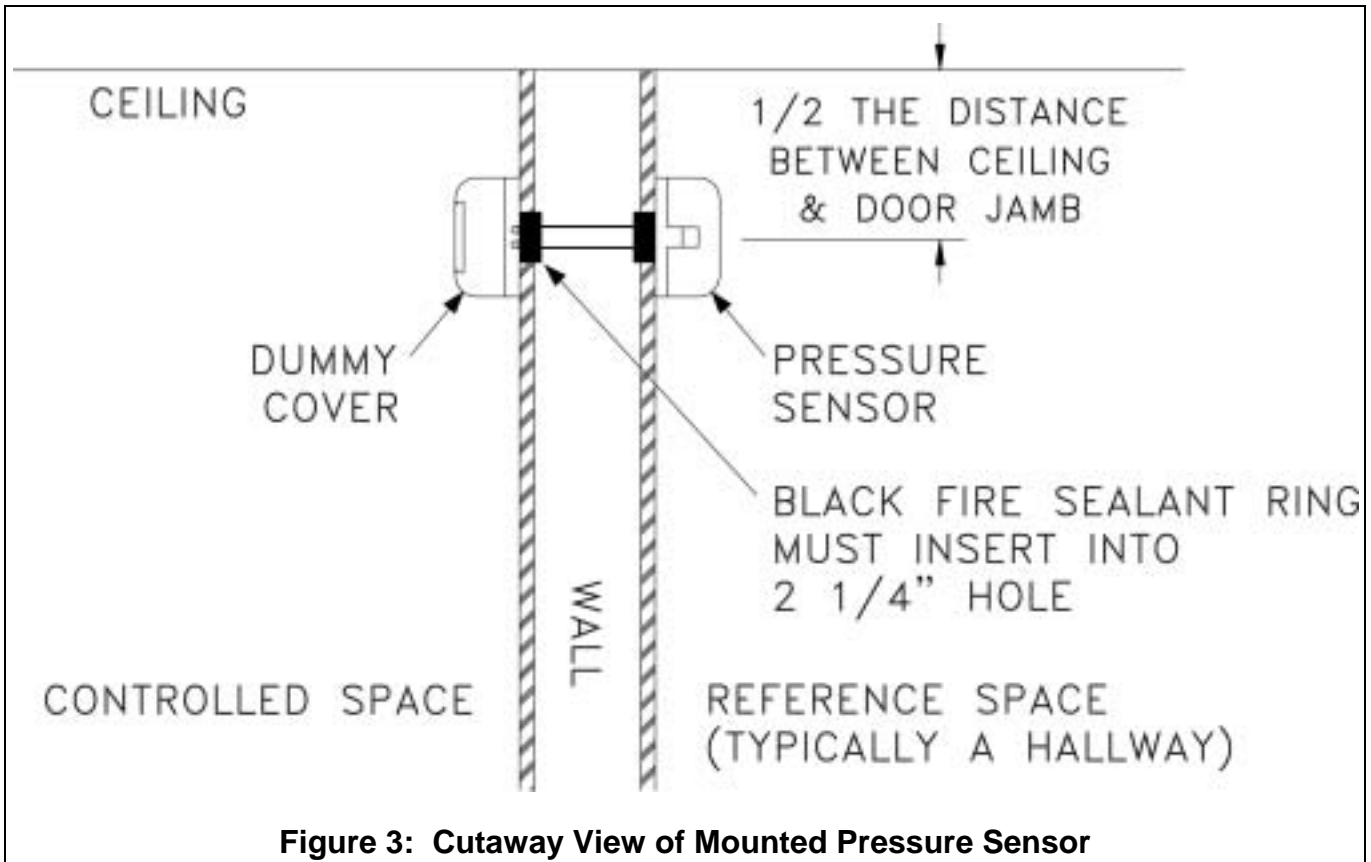

TRANSFORMER INSTALLATION

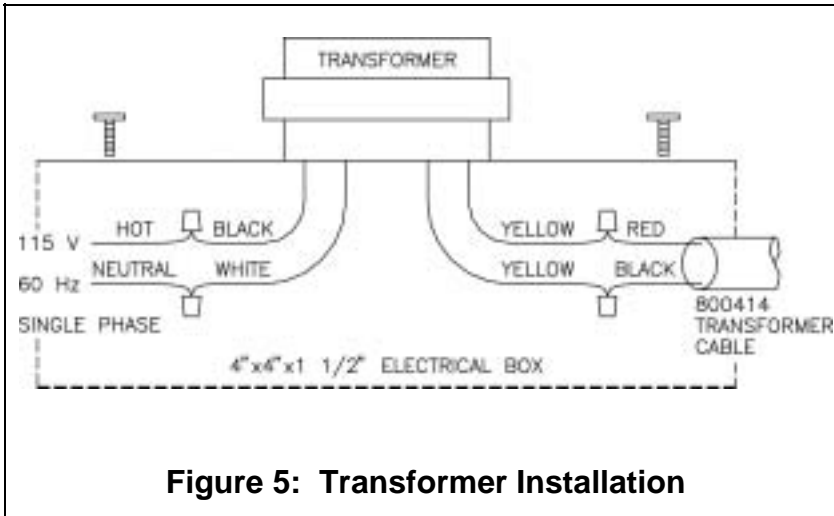

WARNING

Make sure no power is applied until all wiring is complete.

Follow all applicable electrical codes, and have qualified personnel install the transformer.

NOTE

115 Volt, single phase, 60 Hertz power source is required to power the 800420 transformer. If TSI Transformer is not installed, a regulated 24 volt, single phase, 60 Hertz power source is required to power the controller.

- Mount a standard 4" X 4" x 1-1/2" electrical box at a convenient location within 20 feet of pressure monitor.
- Run 115 Volt, single phase, 60 hertz line voltage (115 VAC) to electrical box. Follow all applicable electrical codes.
- Connect 115 VAC line voltage HOT wire to BLACK wire on transformer and NEUTRAL wire to WHITE wire on transformer (Figure 5).
- Connect the RED wire on 800414 transformer cable to either YELLOW wire on the transformer and the BLACK wire to the remaining YELLOW wire.
- Screw the transformer to the electrical box.
- Run transformer cable from the transformer electrical box to the pressure monitor. Have at least 8 inches of cable coming out of the pressure monitor rough in electrical box before trimming cable to length.

PRESSURE MONITOR INSTALLATION

Pressure Monitor Rough-in

- Select the mounting location of the pressure monitor. The construction plans normally show the mounting location. If no location is specified, then the unit is typically installed as shown in Figure 1, either in the laboratory or in the hallway.
- Install a standard double gang electrical box (4" x 4").
- Slide the pressure monitor cover to the right and remove three screws holding the electronics to the base (Figure 6). Remove base.
- Install the base to the 4" x 4" electrical box. The base's "THIS SIDE UP" arrow must be pointing towards the ceiling

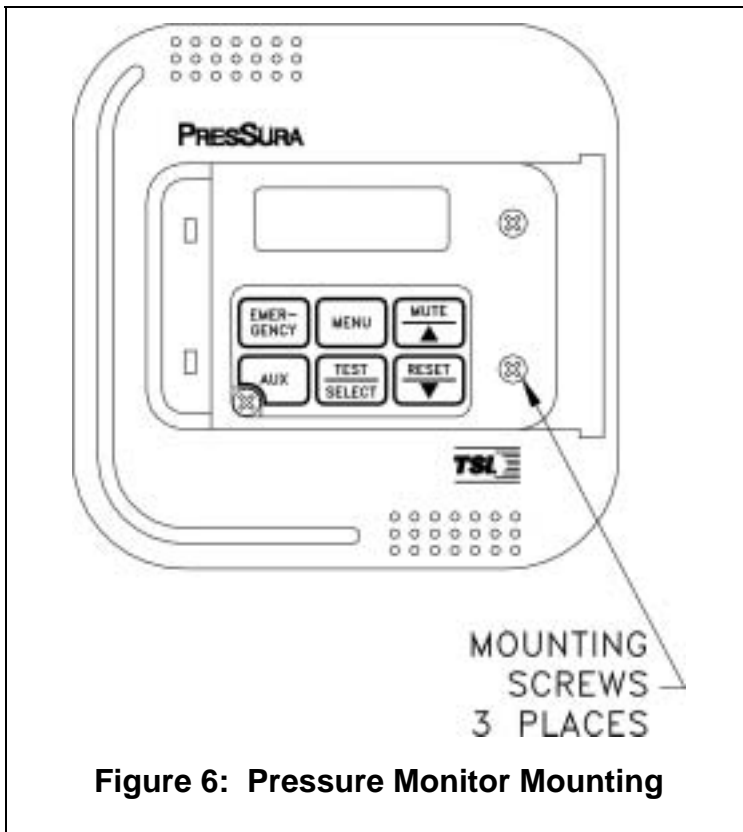

NOTE: Two screws are hidden behind the cover when full open. The cover will slide to the right approximately 2 inches until a stop is hit. Pull cover to completely remove from electronics and expose the screws.

Pressure Monitor Wiring

WARNING: Do **not** connect more than 24 VAC to any terminal.

Do **not** apply voltage to the RS-485 output, analog output, or control output. Severe damage may occur to the unit if voltage is applied.

- Remove the connectors from the back of the pressure monitor.
- Refer to the wiring diagram (Figure 7) for proper wiring installation.
- If additional options need to be wired, refer to building prints for proper wiring diagram.
- Plug the connectors back into the pressure monitor.
- Carefully push the wires into the electrical box and mount the pressure monitor. Install three screws to hold pressure monitor firmly to base. Install cover and slide left to hide display.



MODEL 8635 MONITOR WIRING DIAGRAM

CD-217

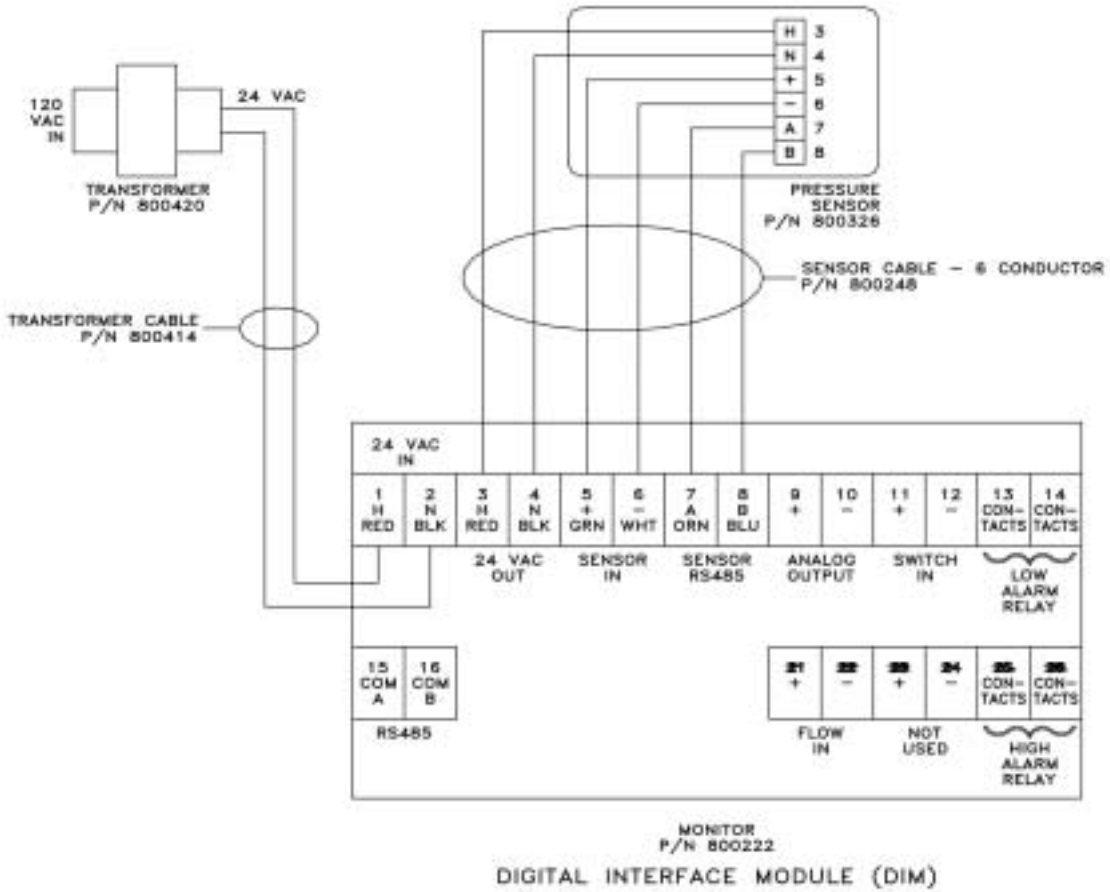

TSI Incorporated
 500 Cardigan Road
 Shoreview, MN 55126
 Telephone: 651-490-2811 Fax: 651-490-3824

ENGINEER:	
SOLD TO:	
PROJECT:	
JOB NO.:	DWG NO.:
REP:	DATE:

7/01/96

COPYRIGHT ©, 1996 BY TSI INCORPORATED

Warning: Monitor must be wired exactly as wire diagram shows. Making modifications to the wiring may severely damage the unit.

Figure 7: Wiring Diagram

NOTE: If you need assistance installing the system, call TSI - HVAC Controls at (800) 874-2811.