

Model 8681 SUREFLOW™ Adaptive Offset Controller Installation Instructions

WARNING: The Model 8681 Adaptive Offset Controller must be wired to 24 VAC only. Wiring the unit to 110 VAC will cause serious unit damage and void the warranty.

These installation instructions guide the installer through the installation of the TSI Model 8681 SUREFLOW™ Adaptive Offset Controller and all TSI options. Some options may not have been provided by TSI, so please review those product installation instructions. Please read these instructions thoroughly before beginning installation.

OVERVIEW

Figure 1 provides an overview of the various components installed. The order the components are installed is not important. The building prints will define the location of the dampers, flow stations, and pressure sensor. If no location is defined, these instructions show “typical” installation locations.

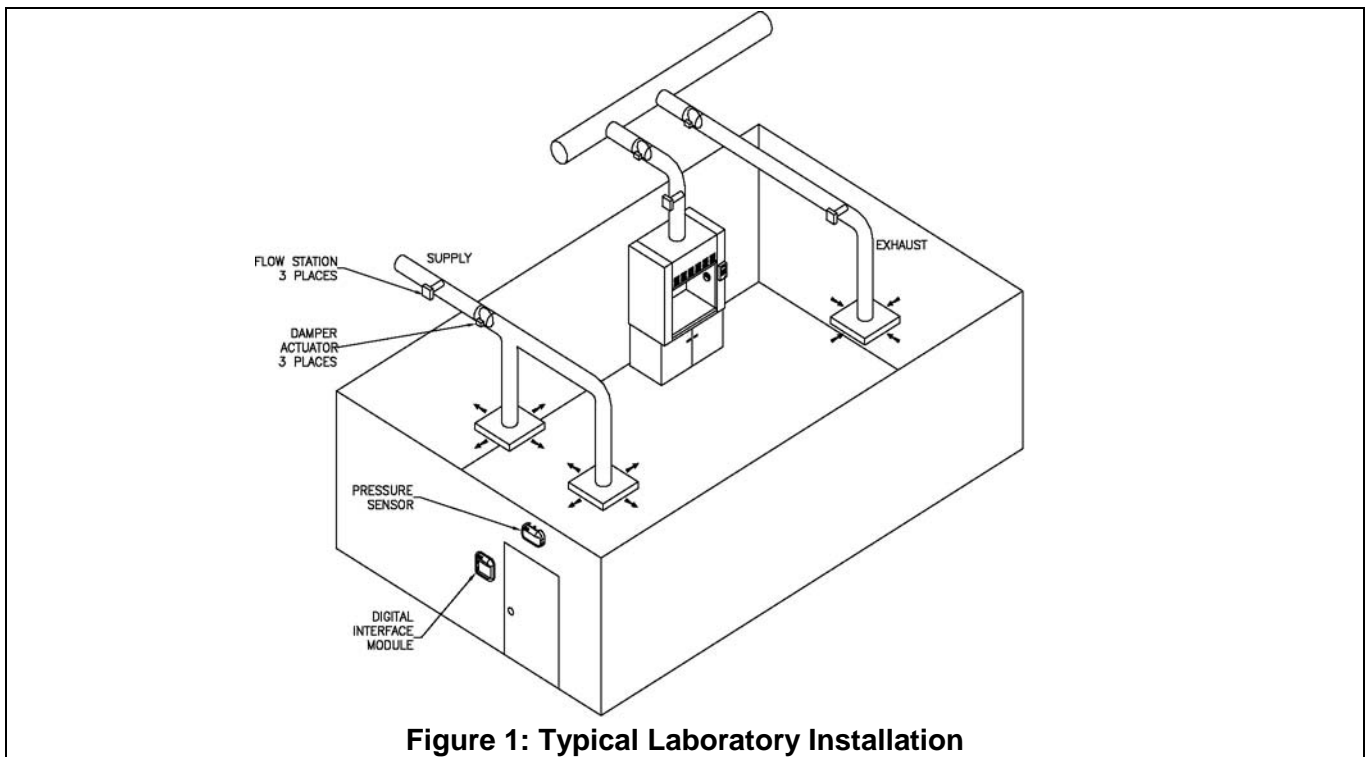

™ SUREFLOW is a trademark of TSI Incorporated.



COMPONENT LIST

NOTE: There are a large variety of options that can be installed with the Adaptive Offset Controller. The system you are installing may or may not have all components or quantity of components listed below.

Only TSI supplied devices, listed below, are covered in these installation instructions. Please refer to the manufacturer's installation instructions for proper installation of non TSI devices.

Adaptive Offset Controller

<u>Part Number</u>	<u>Qty</u>	<u>Description</u>
800776	1	Digital Interface Module / Adaptive Offset Controller (DIM / AOC) with MODBUS
<i>or</i>		
868128	1	Digital Interface Module / Adaptive Offset Controller (DIM / AOC) with BACnet MSTP
800326	1	Pressure sensor (Not on Offset-only controllers)
800248	1	Sensor cable
800420	1	Transformer
800414	1	Transformer cable
1901057	2	Intumescent ring
2923020	1	Fire sealant
800893	1	1000 Ω platinum RTD

Flow Stations (Each Unit)

<u>Part Number</u>	<u>Qty</u>	<u>Description</u>
NONE	1	Flow station - sized to duct (Air Monitor brand)
804139	1	Pressure Transducer (MAMAC brand)
800420	1	Transformer
800414	2	Transformer cable - second cable is for flow station output.

Dampers / Actuators (Each Unit)

<u>Part Number</u>	<u>Qty</u>	<u>Description</u>
None	1	Damper - sized for duct
800420	1	Transformer
800414	2	Transformer cable - second cable is for control signal.
800370	1	Electric actuator

DIGITAL INTERFACE MODULE INSTALLATION

- 1) Select the mounting location of the Digital Interface Module (DIM). The construction plans normally show the mounting location. If no location is specified, then the unit is typically installed as shown in Figure 1, either in the laboratory or in the hallway.
- 2) Install a standard double gang electrical box (4" x 4").
- 3) Slide the DIM cover to the right and remove three screws holding the electronics to the base (Figure 2). Remove base.
- 4) Screw the base to the 4" x 4" electrical box (screws not included). The base's "THIS SIDE UP" arrow must be pointing towards the ceiling.
- 5) Refer to the wiring diagrams for proper wiring (Figures 12 and 13). The cables are terminated both at the DIM, and at the appropriate device.
- 6) Carefully push the wires into the electrical box and mount the DIM. Re-install the three screws to hold DIM firmly to base. Install cover and slide left to hide display.

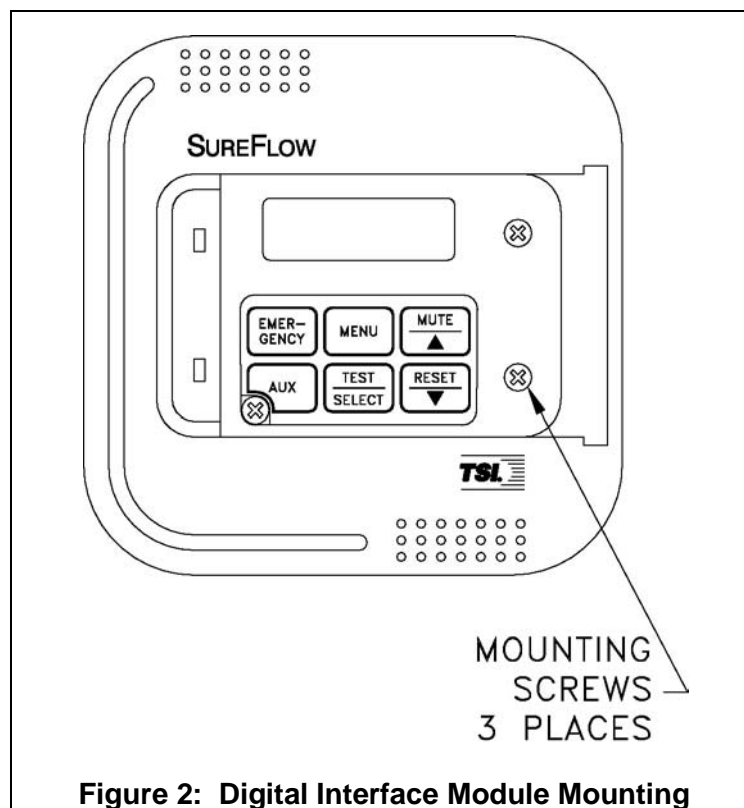

Figure 2: Digital Interface Module Mounting

NOTE: Two screws are hidden behind the cover when full open. The cover will slide to the right approximately 2 inches until a stop is hit. Pull cover to completely remove from electronics and expose the screws.

WIRING

WARNING: Do **not** connect more than 24 VAC to any terminal.

Do **not** apply voltage to the RS-485 output, analog output, or control output. Severe damage may occur to the unit if voltage is applied.

WARNING: Each damper/actuator and flow station has a separate transformer that must be installed. Do **not** wire more than one device per transformer.

- 1) Remove the connectors from the back of DIM.
- 2) Refer to Figures 12 and 13 wiring diagram for pressure sensor, DIM, TSI Damper/actuator, and TSI flow station wiring. Refer to Figure 14 wiring diagram for transformer wiring.

NOTE: If additional options need to be wired, or non TSI components need wiring, refer to building prints for proper wiring diagram.

- 3) Strip $\frac{1}{4}$ " to $\frac{3}{8}$ " insulation from the wires. Twist stranded wire to eliminate loose strands.
- 4) Insert wire into connector and tighten.
- 5) Insert connector into proper receptacle.

PRESSURE SENSOR INSTALLATION



This product is classified by Underwriters Laboratories, Inc.® for use in through-penetration firestop systems. See UL fire resistance directory.

The pressure sensor (P/N 800326) is typically installed above the main entrance to the laboratory (Figure 3).

WARNING: 800326 pressure sensor must be mounted through the wall between the controlled space (laboratory) and referenced space (hallway), exactly as shown in Figure 4.

- 1) Determine pressure sensor location (Figures 3, 4). Pressure sensor typically mounts in the reference space, and the dummy housing mounts in the laboratory.

NOTE: Pressure sensor is not symmetrical. If sensor is to be centered over hallway door, measure one inch to the left of center for 2 1/4" hole. Dummy sensor will be 2" off center on other side of wall.

- 2) The pressure sensor must be orientated on the wall as shown in Figure 5. Looking at the mounted sensor, sensor hole is on the left (2 1/4") and wire hole is on the right.
- 3) Drill a 2 1/4" inch hole through each side of the wall to accept the sensor tube.
- 4) Drill a 7/8-inch hole on the side of the wall that the pressure sensor will be mounted. This hole is for the six-conductor sensor cable. Refer to Figure 5 for a hole mounting pattern.
- 5) Slide sensor cover to right and remove screw that holds the sensor base to the pressure sensor (Figure 5). Remove pressure sensor and store in a safe place.
- 6) From the side of the wall the sensor will be mounted, slide the sensor tube through the wall. Mark the tube where it is flush with wall. Remove sensor tube and cut tube 1/8 inch shorter than flush marking.

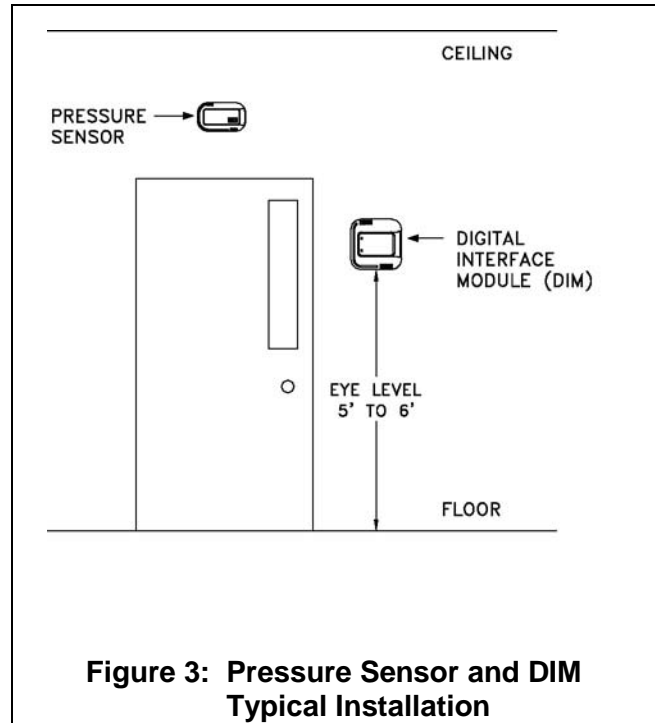

Figure 3: Pressure Sensor and DIM Typical Installation

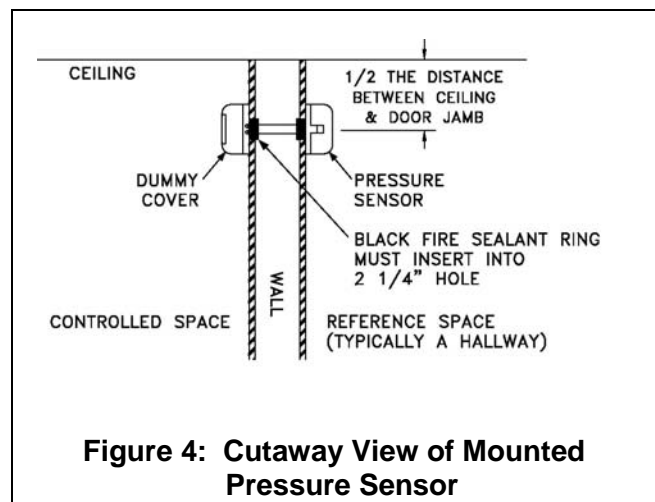

Figure 4: Cutaway View of Mounted Pressure Sensor

NOTE: If 12" sensor tube is not long enough, add a 1" to 2" adapter and extend with 2" OD tube. The base of the dummy housing will need to be drilled out to accommodate 2" tube. Do **not** extend sensor tube with 1" tubing.

- 7) From the side of the wall the sensor will be mounted, slide the sensor tube through the wall. Slide the dummy base over the end of the tube. Screw the pressure sensor base and dummy base to the wall (Figure 6).
- 8) Refer to the wiring diagrams for proper wiring (Figures 12). The sensor cable is terminated at the pressure sensor, and at the DIM.
- 9) Insert fire protection sealant (provided) into $\frac{7}{8}$ " wire hole to seal.
- 10) Install and screw the pressure sensor and dummy cover onto the bases. Slide covers to the left to hide the sensor. Finished installation should look as shown in Figure 6.

Warning: Do **not** touch the sensor element in the pressure sensor. Do **not** run wires through the air passage. Doing so will damage the sensing element.

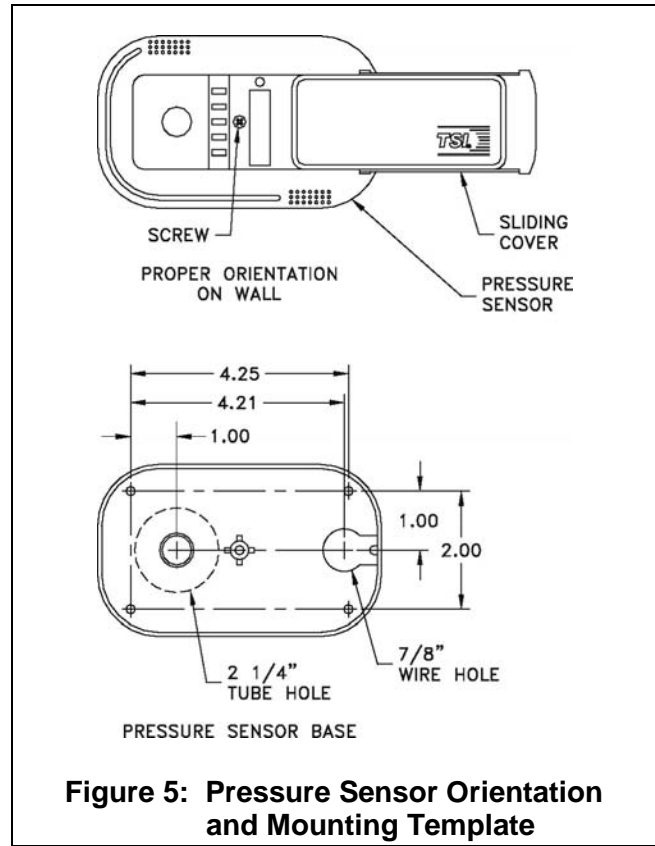

Figure 5: Pressure Sensor Orientation and Mounting Template

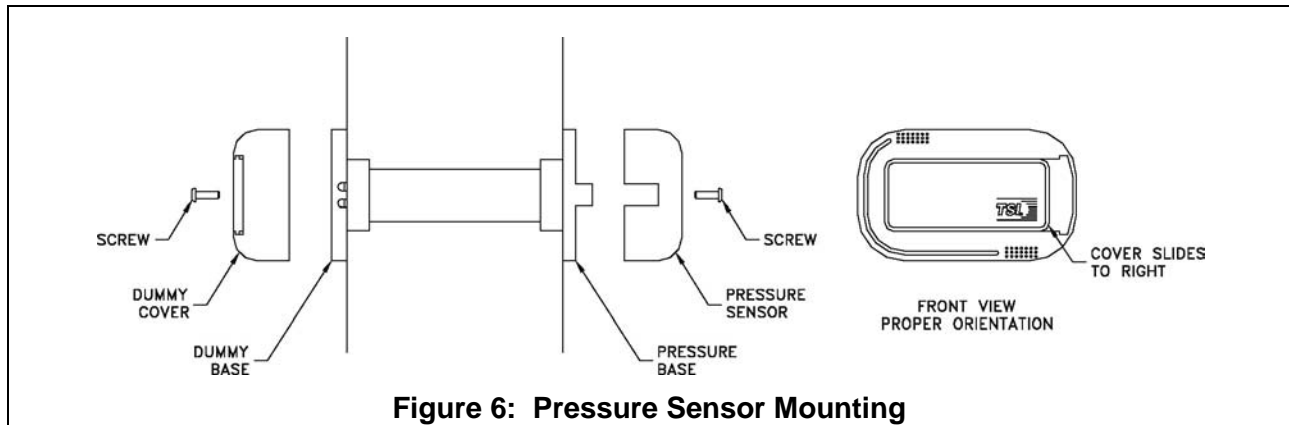

Figure 6: Pressure Sensor Mounting

FLOW STATION INSTALLATION

- 1) Select the mounting location of the flow station.
The construction plans normally show the mounting location. If no location is specified, then typically the flow station is installed upstream of the damper actuator.

WARNING: Figure 7 gives the minimum straight length duct diameters required for the flow station to operate correctly.

TSI recommends installing the flow station upstream of the damper (before). TSI does not recommend installing the flow station downstream (after) the damper. If the flow station must be placed downstream, a minimum of 4 straight duct lengths between the damper and flow station is required. In addition, the flow station must be rotated 90° (perpendicular) from the damper shaft position.

The minimum straight duct lengths shown are the absolute minimum.

- 2) Drill a 1¼" hole in the side of the duct work. If probe is longer than 18 inches, drill a 5/16" hole directly across from the 1¼" hole (Figure 8).
- 3) Slide foam gasket onto flow station, and insert into duct work. Insert the flow station through the 1¼" hole, and into the 5/16" hole (if required). On probes 18 inches or longer attach the nut to the threaded end of the flow station (5/16" hole end).

- 4) Rotate the flow station until the air flow indicator arrow matches the correct direction of air flow.
- 5) Screw the flow station into place with sheet metal screws (screws not provided by TSI). On 18 inch and longer flow stations tighten the 5/16" nut. The finished installation should look like Figure 8.

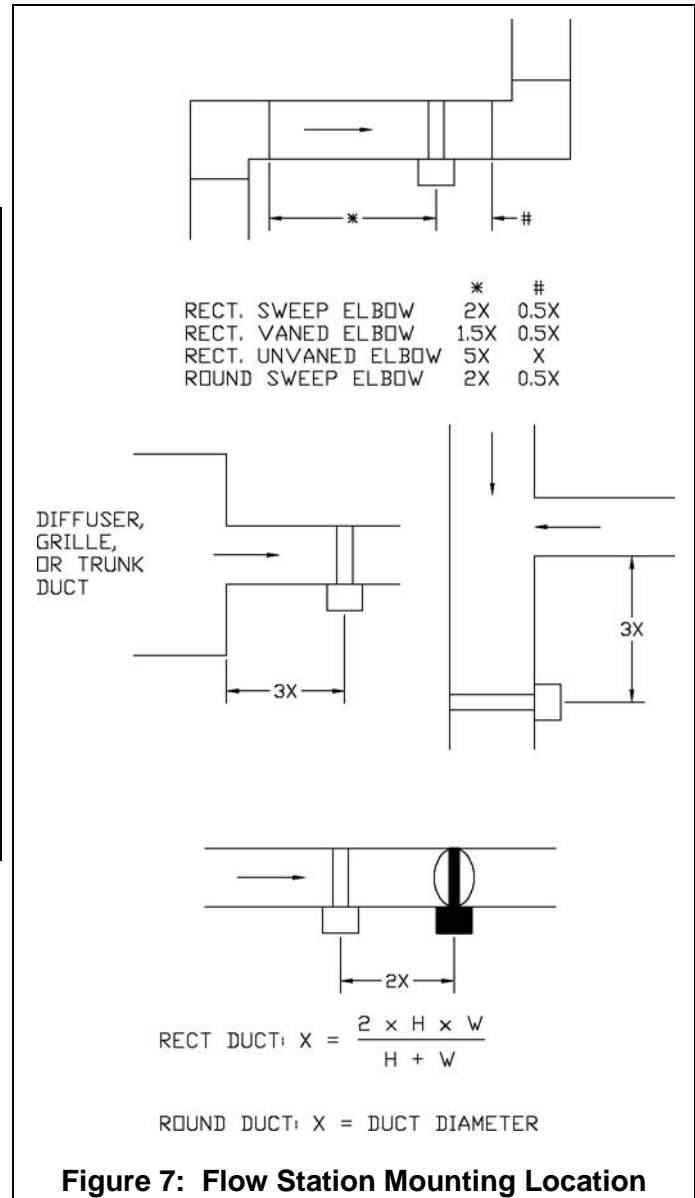

Figure 7: Flow Station Mounting Location

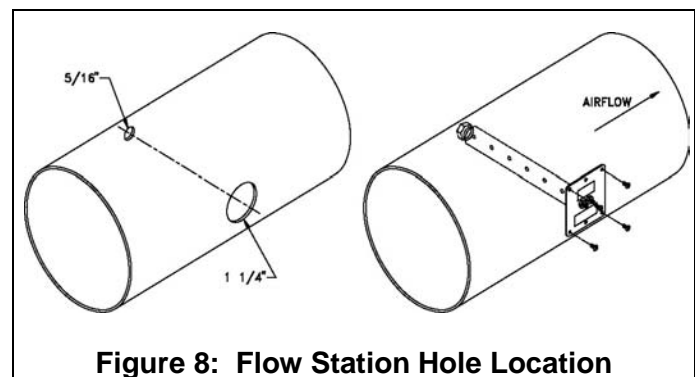

Figure 8: Flow Station Hole Location

- 6) Verify that the jumpers on the pressure transducer are installed correctly, per Figure 9. The default pressure transducer output range is 0 to 0.5 in. H₂O.
- 7) Mount the pressure transducer within 10 feet of the flow station. The transducer must be mounted on a wall in the correct position per Figure 10 (screws not provided).

WARNING: Do **not** mount pressure transducer to ceiling, ductwork or vibrating surfaces. Preferred mounting location is on the wall nearest the flow station.

- 8) Run two ¼” pneumatic lines (20’ included) between flow station and pressure transducer and connect.

Flow Station		Pressure Transducer
Total	<i>to</i>	Hi
Static	<i>to</i>	Lo

Double check that the pneumatic tubing is correctly plumbed, firmly seated, and has a tight fit.

- 9) Refer to the wiring diagrams for proper wiring (Figures 12 and 13). The cable is terminated at the pressure transducer and at the DIM.

WARNING: Do **not** mount pressure transducer to ceiling, ductwork or vibrating surfaces. Preferred mounting location is on the wall nearest the flow station.

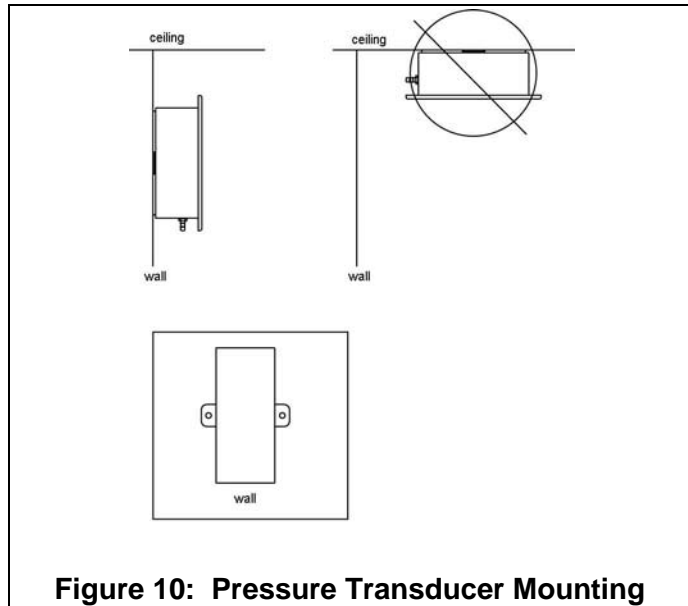
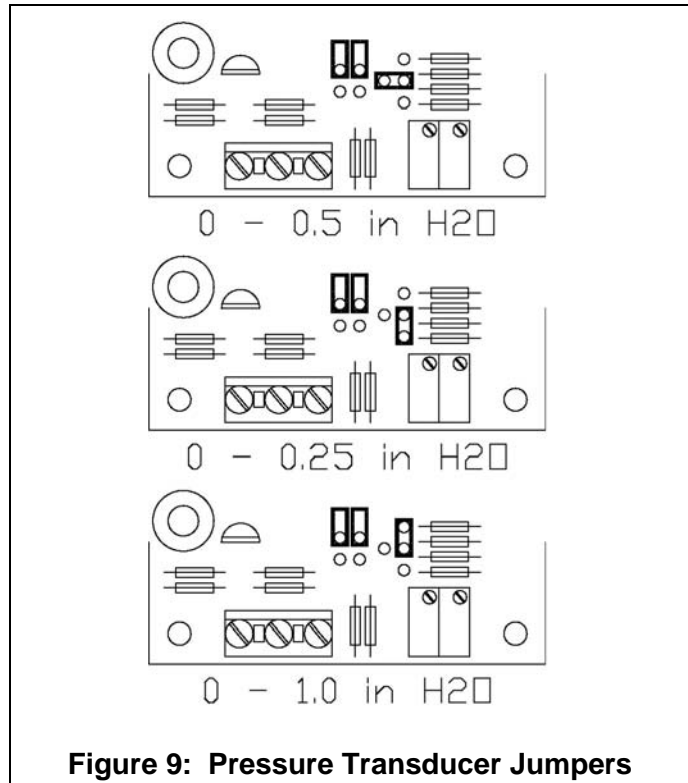

DAMPER/ACTUATOR INSTALLATION

WARNING: Building prints normally determine damper location and mounting configuration. They supersede the guidelines below.

- 1) The actuators are shipped mounted to the damper. No adjustments are needed prior to mounting the assembly.
- 2) The damper must be installed with the damper shaft parallel to the ground (Figure 11).
- 3) Slip-fit dampers mount **INSIDE** the duct work. Flanged dampers bolt to the duct work. No ductwork can be inside of dampers, or interfere with damper rotation.
- 4) Rivet slip-fit damper to duct work to ensure damper rotates correctly. Alternate: use 1-inch or shorter screws. Make sure screws do not interfere with damper blade rotation; damper blade rotates outside of damper sleeve. Bolt flanged dampers securely to ductwork, but do not “force” damper to fit (deforms damper).
- 5) Refer to the wiring diagrams for proper wiring (Figures 12 and 13). The cable is terminated at the damper/actuator and at the DIM.

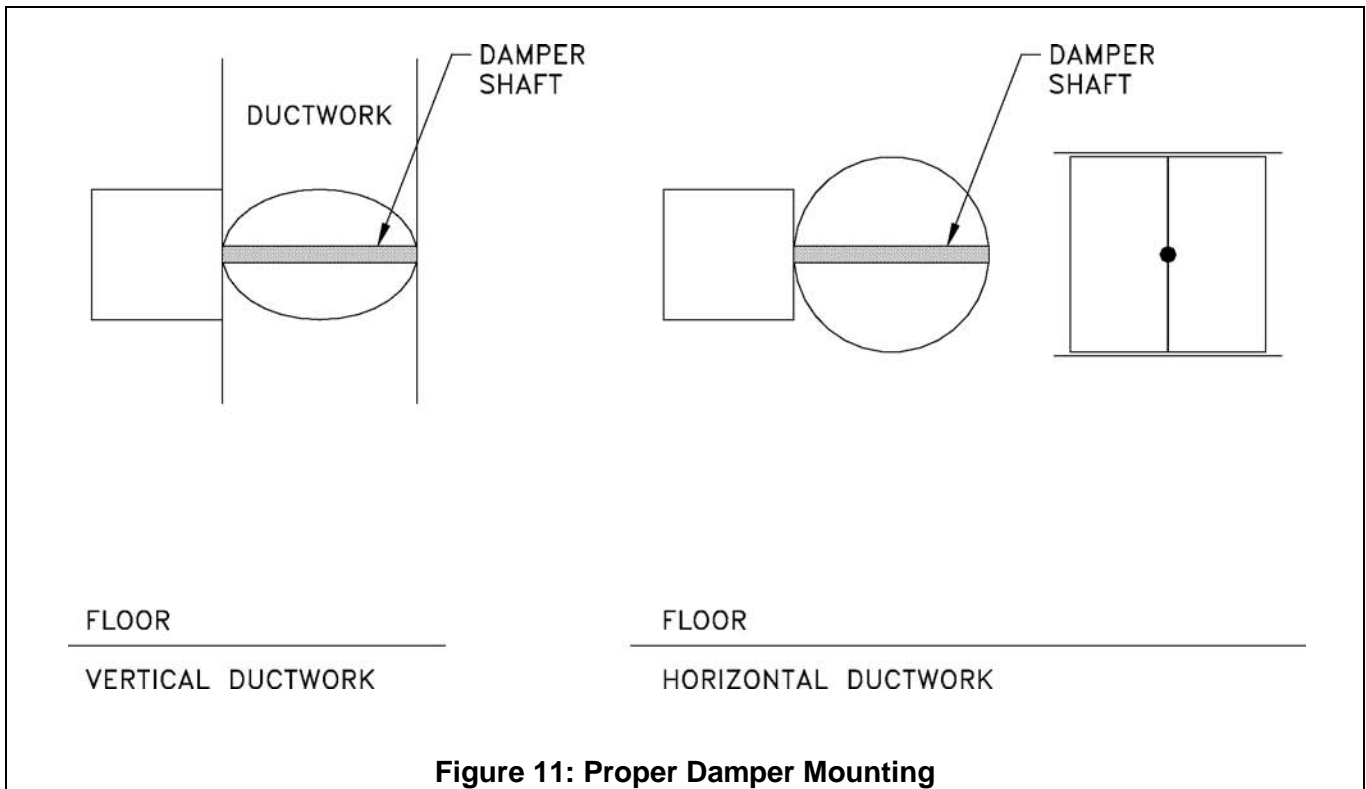
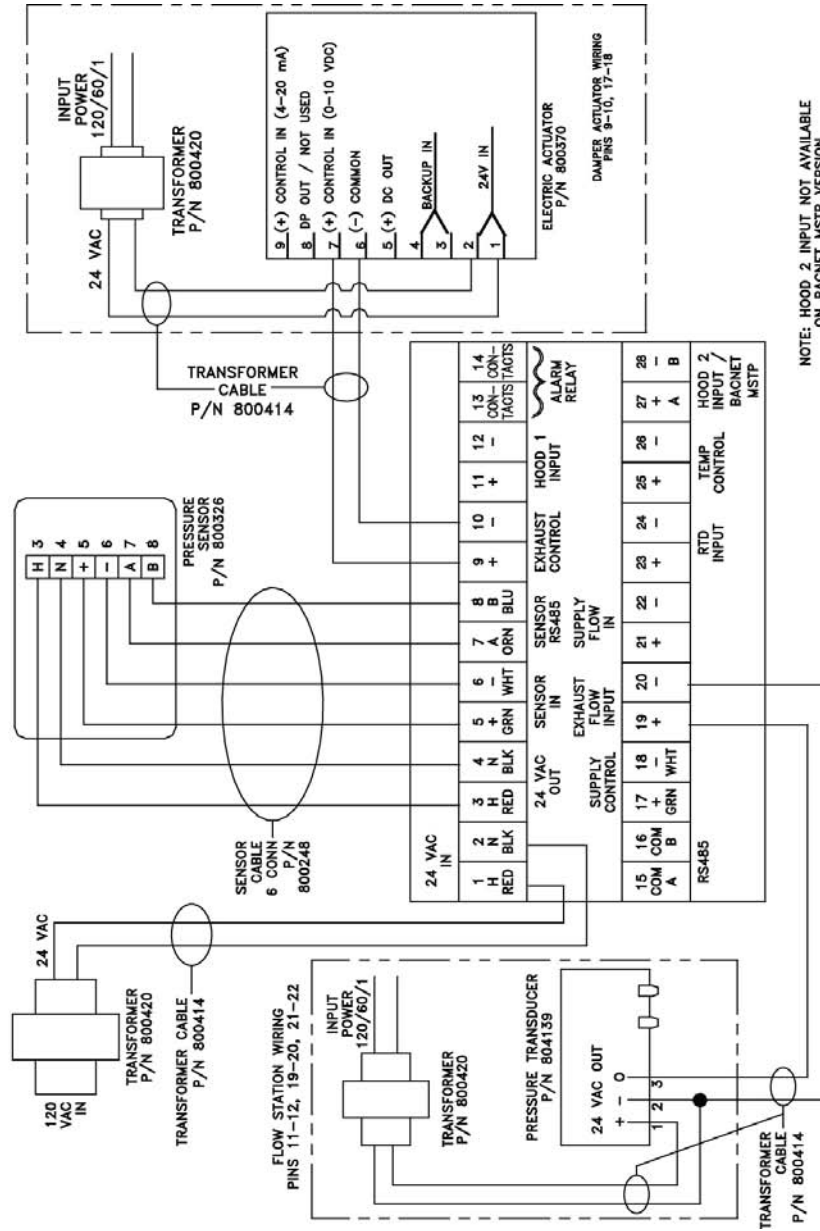

Figure 11: Proper Damper Mounting

Note: Pressure sensor & cable
Not used on offset controller.



NOTE: HOOD 2 INPUT NOT AVAILABLE
ON BACNET MSTP VERSION

CONTROLLER
P/N 800776 (MODBUS VERSION)
P/N 868128 (BACNET MSTP VERSION)
DIGITAL INTERFACE MODULE (DIM)

WARNING: Controller must be wired exactly as wire diagram shows. Making modifications to the wiring may severely damage the unit.

Figure 12: Adaptive Offset Wiring Diagram – Electric Actuator Version

TRANSFORMER INSTALLATION

Transformers are provided for the DIM/AOC, each damper/actuator, and each flow station (TSI).

WARNING: Each damper/actuator and flow station has a separate transformer that must be installed. Do not wire more than one device per transformer.

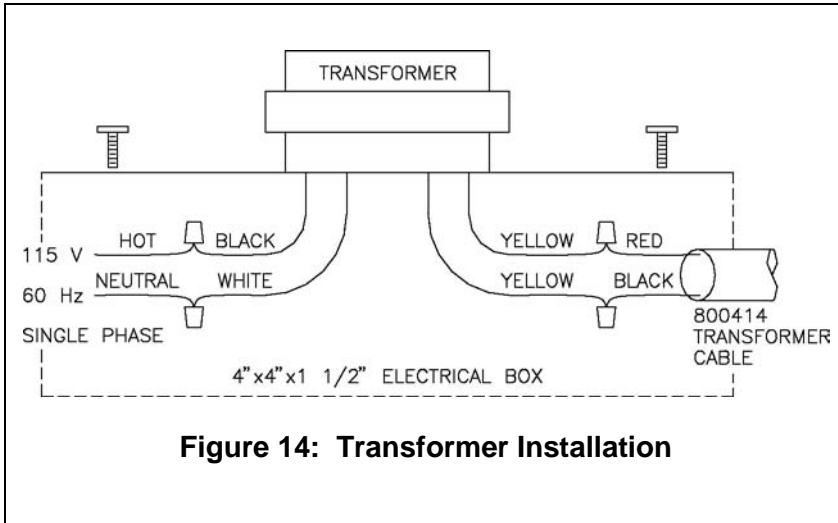

WARNING:

Make sure no power is applied until all wiring is complete.

Follow all applicable electrical codes, and have qualified personnel install the transformer.

NOTE:

115 volt, single phase, 60 Hertz power source is required to power the 800420 transformer. If TSI Transformer is not installed, a regulated 24 volt, single phase, 60 Hertz power source is required to power the controller.

- 1) Mount a standard 4" x 4" x 1½" electrical box at a convenient location within 20 feet (transformer cable is 25' long) of the device being installed: Adaptive Offset Controller, damper/actuator, or flow station. Each device must have a separate transformer. **DO NOT INSTALL MULTIPLE DEVICES ON ONE TRANSFORMER.**
- 2) Run 115 volt, single phase, 60 hertz line voltage (115 VAC) to transformer electrical box. Follow all applicable electrical codes.
- 3) Connect 115 VAC line voltage HOT wire to BLACK wire on transformer and NEUTRAL wire to WHITE wire on transformer (Figure 14).
- 4) Connect the RED wire on 800414 transformer cable to either YELLOW wire on the transformer and the BLACK wire to the remaining YELLOW wire.
- 5) Screw the transformer to the electrical box.
- 6) Run transformer cable from the transformer electrical box to the device. Have at least 8 inches of extra cable at the device before trimming cable to length. Wire devices per Figures 12 and 13.

NOTE: If you need assistance installing the system, call TSI Customer Service at (800) 874-2811.

TSI Incorporated – 500 Cardigan Road, Shoreview, MN 55126 U.S.A

USA	Tel: +1 800 874 2811	E-mail: answers@tsi.com	Website: www.tsi.com
UK	Tel: +44 149 4 459200	E-mail: tsiuk@tsi.com	Website: www.tsiinc.co.uk
France	Tel: +33 491 11 87 64	E-mail: tsifrance@tsi.com	Website: www.tsiinc.fr
Germany	Tel: +49 241 523030	E-mail: tsigmbh@tsi.com	Website: www.tsiinc.de
India	Tel: +91 80 41132470	E-mail: tsi-india@tsi.com	
China	Tel: +86 10 8251 6588	E-mail: tsibeijing@tsi.com	
Singapore	Tel: +65 6595 6388	E-mail: tsi-singapore@tsi.com	



TRUST. SCIENCE. INNOVATION.

Contact your local TSI Distributor or visit our website www.tsi.com for more detailed specifications.