

Models 8681 8681-BAC

SUREFLOW™
Adaptive Offset Controller

Operation and Service Manual

P/N 1980476, Revision D
January 2008



TRUST. SCIENCE. INNOVATION.

Models 8681 8681-BAC

SUREFLOW™
Adaptive Offset Controller

Operation and Service Manual

P/N 1980476, Revision D
January 2008

U.S. AND CANADA

Sales & Customer Service:

(800) 874-2811/(651) 490-2811

Fax:

(651) 490-3824

SHIP/MAIL TO:

TSI Incorporated
ATTN: Customer Service
500 Cardigan Road
Shoreview, MN 55126
USA

OTHER COUNTRIES

Sales & Customer Service:

(001 651) 490-2811

Fax:

(001 651) 490-3824

E-MAIL

answers@tsi.com

WEB SITE

www.tsi.com



Copyright ©- TSI Incorporated / January 2008 / All rights reserved.

Part number 1980476 Rev. D

LIMITATION OF WARRANTY AND LIABILITY

Seller warrants the goods sold hereunder, under normal use and service as described in the operator's manual, shall be free from defects in workmanship and material for twenty-four (24) months, or the length of time specified in the operator's manual, from the date of shipment to the customer. This warranty period is inclusive of any statutory warranty. This limited warranty is subject to the following exclusions:

- a. Hot-wire or hot-film sensors used with research anemometers, and certain other components when indicated in specifications, are warranted for 90 days from the date of shipment.
- b. Parts repaired or replaced as a result of repair services are warranted to be free from defects in workmanship and material, under normal use, for 90 days from the date of shipment.
- c. Seller does not provide any warranty on finished goods manufactured by others or on any fuses, batteries or other consumable materials. Only the original manufacturer's warranty applies.
- d. Unless specifically authorized in a separate writing by Seller, Seller makes no warranty with respect to, and shall have no liability in connection with, goods which are incorporated into other products or equipment, or which are modified by any person other than Seller.

The foregoing is IN LIEU OF all other warranties and is subject to the LIMITATIONS stated herein. **NO OTHER EXPRESS OR IMPLIED WARRANTY OF FITNESS FOR PARTICULAR PURPOSE OR MERCHANTABILITY IS MADE.**

TO THE EXTENT PERMITTED BY LAW, THE EXCLUSIVE REMEDY OF THE USER OR BUYER, AND THE LIMIT OF SELLER'S LIABILITY FOR ANY AND ALL LOSSES, INJURIES, OR DAMAGES CONCERNING THE GOODS (INCLUDING CLAIMS BASED ON CONTRACT, NEGLIGENCE, TORT, STRICT LIABILITY OR OTHERWISE) SHALL BE THE RETURN OF GOODS TO SELLER AND THE REFUND OF THE PURCHASE PRICE, OR, AT THE OPTION OF SELLER, THE REPAIR OR REPLACEMENT OF THE GOODS. IN NO EVENT SHALL SELLER BE LIABLE FOR ANY SPECIAL, CONSEQUENTIAL OR INCIDENTAL DAMAGES. SELLER SHALL NOT BE RESPONSIBLE FOR INSTALLATION, DISMANTLING OR REINSTALLATION COSTS OR CHARGES. No Action, regardless of form, may be brought against Seller more than 12 months after a cause of action has accrued. The goods returned under warranty to Seller's factory shall be at Buyer's risk of loss, and will be returned, if at all, at Seller's risk of loss.

Buyer and all users are deemed to have accepted this LIMITATION OF WARRANTY AND LIABILITY, which contains the complete and exclusive limited warranty of Seller. This LIMITATION OF WARRANTY AND LIABILITY may not be amended, modified or its terms waived, except by writing signed by an Officer of Seller.

SERVICE POLICY

Knowing that inoperative or defective instruments are as detrimental to TSI as they are to our customers, our service policy is designed to give prompt attention to any problems. If any malfunction is discovered, please contact your nearest sales office or representative, or call TSI's Customer Service department at (800) 874-2811 or (651) 490-2811.

TRADEMARKS

SUREFLOW™ is a trademark of TSI Incorporated.

CONTENTS

HOW TO USE THIS MANUAL	1
PART ONE	1
User Basics.....	1
The Instrument.....	1
Operator Panel.....	3
Alarms.....	5
Before Calling TSI.....	6
PART TWO	7
Technical Section.....	7
Software Programming.....	7
Menu and Menu Items.....	11
Setup / Checkout.....	44
Calibration.....	51
Maintenance and Repair Parts.....	55
APPENDIX A	57
Specifications.....	57
APPENDIX B	59
Network Communications.....	59
Modbus Communications.....	59
8681 BACnet MS/TP Protocol Implementation Conformance Statement.....	63
Model 8681-BAC BACnet MS/TP Object Set.....	65
APPENDIX C	67
Wiring Information.....	67
APPENDIX D	71
Access Codes.....	71

How to Use This Manual

The SUREFLOW Operation and Service Manual is divided into two parts. Part one describes how the SUREFLOW unit functions and how to interface with the device. This section should be read by users, facilities staff, and anyone who requires a basic understanding of how the SUREFLOW operates.

Part two describes the technical aspects of the product which includes operation, calibration, configuration, and maintenance. Part two should be read by personnel programming or maintaining the unit. TSI recommends thoroughly reading this manual before changing any software items.

NOTE: This operation and service manual assumes proper SUREFLOW installation. Refer to the Installation Instructions to determine if the SUREFLOW has been properly installed.

PART ONE

User Basics

Part one provides a brief but thorough overview of the SUREFLOW product by maximizing information with minimal reading. These few pages explain the purpose (The Instrument), and the operation (Useful User Information, Digital Interface Module, Alarms) of the unit. Technical product information is available in Part Two of the manual. The manual focuses on laboratory spaces; however, the information is accurate for any room pressure application.

The Instrument

The SUREFLOW Adaptive Offset Controller (AOC) maintains laboratory pressure and air balance. The AOC measures and controls all airflow into and out of the laboratory, and measures the pressure differential. Proper laboratory pressure differential provides safety by controlling airborne contaminants that can adversely affect workers in the laboratory, people in the laboratory vicinity, and experiments. For example, laboratories with fume hoods have negative room pressure (air flowing into the room), to minimize exposure to people outside the laboratory. The fume hood is the first level of containment, and the laboratory space is the second level of containment.

Room pressure, or pressure differential, is created when one space (hallway) is at a different pressure than an adjoining space (laboratory). The Adaptive Offset Controller (AOC) creates a pressure differential by modulating supply air into and exhaust air out of the laboratory (hallway space is a constant volume system). The theory is that if more air is exhausted out than is supplied, the laboratory will be negative compared to the hallway. A set offset may not maintain an adequate pressure differential under all conditions. The AOC compensates for the unknown pressure differential by mounting a pressure differential sensor between the hallway and laboratory that confirms correct pressure differential is being maintained. If pressure is not being maintained, the AOC modulates the supply or exhaust air until pressure is maintained.

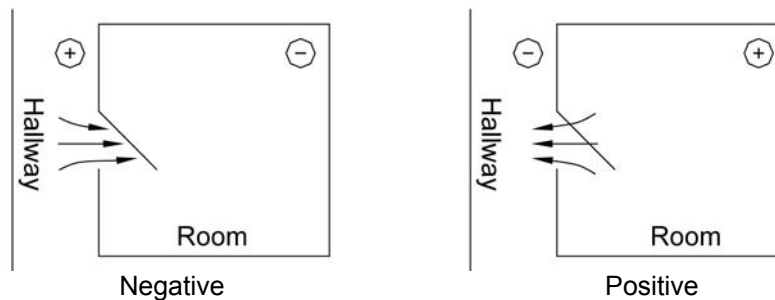

Figure 1: Room Pressure

Negative room pressure is present when air flows from a hallway into the laboratory. If air flows from the laboratory into the hallway, the room is under positive pressure. Figure 1 gives a graphic example of positive and negative room pressure.

An example of negative pressure is a bathroom with an exhaust fan. When the fan is turned on, air is exhausted out of the bathroom creating a slight negative pressure when compared to the hallway. This pressure differential forces air to flow from the hallway into the bathroom.

The SUREFLOW device informs the laboratory users when the laboratory is under proper pressure, and provides alarms when the room pressure is inadequate. If the room pressure is in the safe range, a green light is on. If the pressure is inadequate, a red alarm light and audible alarm turn on.

The SUREFLOW consists of two pieces: a pressure sensor, and Digital Interface Module (DIM) / Adaptive Offset Controller (AOC). The AOC is internally part of the DIM module. The components are typically located as follows; pressure sensor above the laboratory entrance, DIM / AOC is mounted close to the entrance to the laboratory. The pressure sensor continuously measures the room pressure and provides room pressure information to the DIM / AOC. The DIM / AOC continuously reports the room pressure and activates the alarms when necessary. The DIM / AOC controls the supply and exhaust dampers to maintain the pressure differential. The DIM / AOC is a closed loop controller that is continuously measuring, reporting, and controlling room pressure.

Useful User Information

The DIM has a green light and red light to indicate room pressure status. The green light is on when the room has proper room pressure. The red light comes on when an alarm condition exists.

Sliding the door panel to the right reveals a digital display and keypad (Figure 2). The display shows detailed information about room pressure, alarms, etc. The keypad allows you to test the device, put the device into emergency mode, and program or change the device parameters.

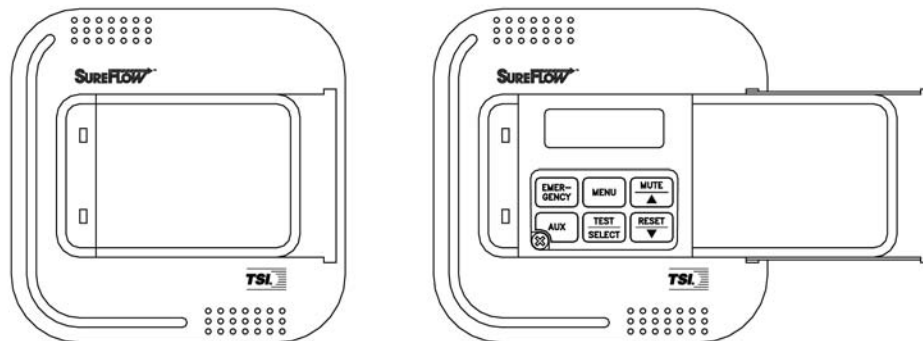

Figure 2: Digital Interface Module (DIM)

SUREFLOW has two levels of user information:

1. SUREFLOW has a red light and green light to provide continuous information on room pressure status.
2. SUREFLOW has a hidden operator panel providing detailed room status information, self-testing capabilities, and access to the software programming functions.

NOTE: The unit provides continuous room pressure status through the red and green light. The operator panel is normally closed unless further information on room pressure status is needed, or software programming is required.

Operator Panel

The DIM in Figure 3 shows the location of the digital display, keypad and lights. An explanation of the operator panel follows the figure.

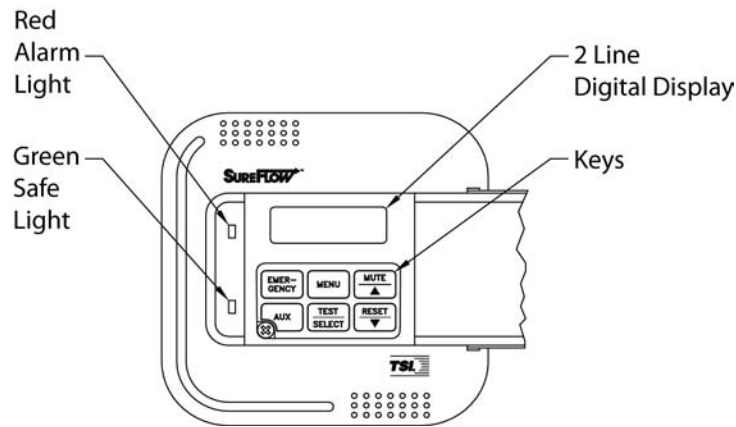

Figure 3: SUREFLOW Operator Panel - Open

Green / Red Light

The green light is on when all the conditions for proper room pressure are adequate. This light indicates the laboratory is operating safely. If any of the room pressure conditions cannot be satisfied, the green light turns off and the red alarm light turns on.

Operator Panel

A cover hides the operator panel. Sliding the door panel to the right exposes the operator panel (Figure 2).

Digital Display

The alphanumeric digital display is a two-line display that indicates actual room pressure (positive or negative), alarm status, menu options, and error messages. In normal operation (green light is on), the display indicates information about room pressure. If an alarm condition occurs, the display changes from

STANDARD		STANDARD
NORMAL	<i>to read</i>	ALARM = *

* states type of alarm; low pressure, high pressure, flow

When programming the unit, the display changes and now shows menus, menu items, and current value of the item, depending on the specific programming function being performed.

NOTE: The AOC system controls room pressure without a pressure sensor installed. However, verification that room pressure is being maintained is not possible. The display will not indicate room pressure or room pressure status when no pressure sensor is installed. The alarms can be programmed to indicate when low supply or exhaust flow is present.

Keypad

The keypad has six keys. The gray keys with black letters are user information keys. In normal operation these keys are active. Additionally, the red emergency key is active. The gray keys with blue characters are used to program the unit. A thorough description of each key is given on the next two pages.

User Keys - Gray with Black Letters

The four keys with black letters provide you information without changing the operation or the function of the unit.

TEST Key

The **TEST** key initiates an instrument self-test. Pressing the **TEST** key activates a scrolling sequence on the display that shows the product model number, software version, and all setpoint and alarm values. The unit then performs a self-test that tests the display, indicator lights, audible alarm, and internal electronics to ensure they are operating properly. If a problem with the unit exists, **DATA ERROR** is displayed. You should have qualified personnel determine the problem with the unit.

RESET Key

The **RESET** key performs three functions. 1) Resets the alarm light, alarm contacts, and audible alarm when in a latched or non-automatic reset mode. The DIM must return to the safe or normal range before the **RESET** key will operate. 2) Resets the emergency function after the emergency key has been pressed (see **EMERGENCY** key). 3) Clears any displayed error messages.

MUTE Key

The **MUTE** key temporarily silences the audible alarm. The time the alarm is temporarily silenced is programmable by you (see **MUTE TIMEOUT**). When the mute period ends, the audible alarm turns back on if the alarm condition is still present.

NOTE: You can program the audible alarm to be permanently turned off (see **AUDIBLE ALM**).

AUX Key

The **AUX** key is active only in specialty applications and is not used on the standard SUREFLOW. If the **AUX** key is used, a separate manual supplement explains the **AUX** key function.

Programming Keys - Gray with Blue Characters

The four keys with blue print are used to program or configure the unit to fit a particular application.

WARNING: Pressing these keys changes how the unit functions, so please thoroughly review the manual before changing menu items.

MENU Key

The **MENU** key performs three functions. 1) Provides access to the menus when in the normal operating mode. 2) When the unit is being programmed, the **MENU** key acts as an escape key to remove you from an item or menu, without saving data. 3) Returns the unit to the normal operating mode. The **MENU** key is further described in the **Software Programming** section of this manual.

SELECT Key

The **SELECT** key performs three functions. 1) Provides access to specific menus. 2) Provides access to menu items. 3) Saves data. Pressing the key when finished with a menu item saves the data, and exits you out of the menu item.

▲/▼ Keys

The **▲/▼** keys are used to scroll through the menus, menu items, and through the range of item values that can be selected. Depending on the item type the values may be numerical, specific properties (on / off), or a bar graph.

Emergency Key - Red with Black Letters

EMERGENCY Key

The red **EMERGENCY** key puts the controller into emergency mode. If the room is under negative room pressure control, the emergency mode maximizes the negative pressure. Conversely, if the room is under positive room pressure control, the emergency mode maximizes the positive pressure.

Pressing the **EMERGENCY** key causes the display to flash "EMERGENCY", the red alarm light to flash on and off, and the audible alarm to beep intermittently. To return to control mode press the **EMERGENCY** or **RESET** key.

Alarms

SUREFLOW has visual (red light) and audible alarms to inform you of changing conditions. The alarm levels (setpoints) are determined by administrative personnel, Industrial Hygienists, or the facilities group depending on the organization.

The alarms, audible and visual, activate whenever the preset alarm level is reached. Depending on the SUREFLOW items installed, programmed alarms activate when room pressure is low or inadequate, when room pressure is high or too great, or when the supply or general exhaust air flow is insufficient. When the laboratory is operating safely, no alarms sound.

Example: The low alarm is programmed to activate when the room pressure reaches -0.001 inches H_2O . When the room pressure drops below -0.001 inches H_2O (gets closer to zero), the audible and visual alarms activate. The alarms turn off (when set to unlatched) when the unit returns to the safe range which is defined as negative pressure greater than -0.001 inches H_2O .

Visual Alarm Operation

The red light on the front of the unit indicates an alarm condition. The red light is on for all alarm conditions, low alarms, high alarms, and emergency. The light is on continuously in a low or high alarm condition, and flashes in an emergency condition.

Audible Alarm Operation- EMERGENCY key

When the **EMERGENCY** key is pressed, the audible alarm beeps intermittently until the **EMERGENCY** or **RESET** key is pressed terminating the emergency alarm. The emergency alarm cannot be silenced by pressing the **MUTE** key.

Audible Alarms - All Except Emergency

The audible alarm is continuously on in all low and high alarm conditions. The audible alarm can be temporarily silenced by pressing the **MUTE** key. The alarm is silent for a period of time (see **MUTE TIMEOUT** to program time period). When the time out period ends, the audible alarm turns back on if the alarm condition is still present.

You can program the audible alarm to be permanently turned off (see **AUDIBLE ALM**). The red alarm light still turns on in alarm conditions when audible alarm is turned off. The audible and visual alarms can be programmed to either automatically turn off when the unit returns to the safe range or to stay in alarm until the **RESET** key is pressed (See **ALARM RESET**).

Before Calling TSI

This manual should answer most questions and resolve most problems you may encounter. If you need assistance or further explanation, contact your local TSI representative or TSI. TSI is committed to providing high quality products backed by outstanding service.

Please have the following information available prior to contacting your authorized TSI Manufacturer's Representative or TSI:

- Model number of unit* 8681- _____
- Software revision level*
- Facility where unit is installed

* First two items that scroll when **TEST** key is pressed

Due to the different SUREFLOW models available, the above information is needed to accurately answer your questions.

For the name of your local TSI representative or to talk to TSI service personnel, please call TSI at:

U.S. AND CANADA

Sales & Customer Service:

(800) 874-2811/(651) 490-2811

Fax:

(651) 490-3824

SHIP/MAIL TO:

TSI Incorporated

ATTN: Customer Service

500 Cardigan Road

Shoreview, MN 55126

USA

OTHER COUNTRIES

Sales & Customer Service:

(001 651) 490-2811

Fax:

(001 651) 490-3824

E-MAIL

answers@tsi.com

WEB SITE

www.tsi.com

PART TWO

Technical Section

The AOC is ready to use after being properly installed. Please note that the AOC is part of the DIM module and is not a separate component. Where AOC is written, the overall control sequence is being discussed. When DIM is written, the manual is referring to programming the unit or viewing what is on the display. The pressure sensor is factory calibrated prior to shipping and should not need adjustment. The flow stations need a zero point and/or a span programmed prior to using them. The Digital Interface Module (DIM) is programmed with a default configuration that can be easily modified to fit your application.

The Technical section is separated into five parts that cover all aspects of the unit. Each section is written as independently as possible to minimize flipping back and forth through the manual for an answer.

The [Software Programming](#) section explains the programming keys on the DIM. In addition, the programming sequence is described, which is the same regardless of the menu item being changed. At the end of this section is an example of how to program the DIM.

The [Menu and Menu Item](#) section lists all of the software items available to program and change. The items are grouped by menu which means all setpoints are in one menu, alarm items in another, etc. The menu items and all related information are listed in table format and include menu item name, description of menu item, range of programmable values, and how the unit shipped from the factory (default values).

The [Setup / Checkout](#) section; explains the AOC controller theory of operation, lists the menu items that need to be programmed for the system to operate, provides a programming example, and provides information to confirm system is operating correctly.

The [Calibration](#) section describes the required technique to compare the pressure sensor reading to a thermal anemometer, and how to adjust the zero and span to obtain an accurate calibration. This section also describes how to zero a TSI flow station transducer.

The [Maintenance and Repair Parts](#) section covers all routine maintenance of equipment, along with a list of repair parts.

Software Programming

Programming the SUREFLOW is quick and easy if the programming keys are understood and the proper key stroke procedure is followed. The programming keys are defined first, followed by the required keystroke procedure. At the end of this section is a programming example.

NOTE: The unit is always operating while programming unit (except when checking the control outputs). When a menu item value is changed, the new value takes effect *immediately* after saving the change.

NOTE: This section covers programming the instrument through the keypad and display. If programming through RS-485 communications, use the host computer's procedure. The changes take place immediately upon "saving data."

Programming Keys

The four keys with blue characters (refer to Figure 4) are used to program or configure the unit to fit your particular application. Programming the instrument changes how the unit functions, so thoroughly review the items to be changed.

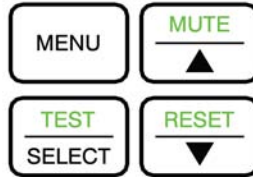

Figure 4. Programming Keys

MENU Key

The **MENU** key has three functions.

1. The **MENU** key is used to gain access to the menus when the unit is in the normal operating mode. Pressing the key once exits the normal operating mode and enters the programming mode. When the **MENU** key is first pressed, the first two menus are listed.
2. When the unit is being programmed, the **MENU** key acts like an escape key.
 - When scrolling through the main menu, pressing the **MENU** key returns the unit to standard operating mode.
 - When scrolling through the items on a menu, pressing the **MENU** key returns you to the list of menus.
 - When changing data in a menu item, pressing the **MENU** key escapes out of the item without saving changes.
3. When programming is complete, pressing the **MENU** key returns the unit to normal operating mode.

SELECT Key

The **SELECT** key has three functions.

1. The **SELECT** key is used to gain access to specific menus. To access a menu, scroll through the menus (using arrow keys) and place the flashing cursor on the desired menu. Press the **SELECT** key to select the menu. The first line on the display will now be the selected menu and the second line shows the first menu item.
2. The **SELECT** key is used to gain access to specific menu items. To access a menu item scroll through the menu items until item appears. Press the **SELECT** key and the menu item now appears on the first line of the display and the second line shows the item value.
3. Pressing the **SELECT** key when finished changing an item saves the data and exits back to the menu items. An audible tone (3 beeps) and visual display (“saving data”) gives confirmation data is being saved.

▲/▼ Keys

The ▲/▼ keys are used to scroll through the menus, menu items, and through the range of item values that can be selected. Depending on the menu item selected the value may be numerical, specific property (on / off), or a bar graph.

NOTE: When programming a menu item, continuously pressing the arrow key scrolls through the values faster than if arrow key is pressed and released.

Keystroke Procedure

The keystroke operation is consistent for all menus. The sequence of keystrokes is the same regardless of the menu item being changed.

1. Press the **MENU** key to access the main menu.
2. Use the ▲/▼ keys to scroll through the menu choices. The blinking cursor needs to be on the first letter of the menu you want to access.
3. Press the **SELECT** key to access chosen menu.
4. The menu selected is now displayed on line one and the first menu item is displayed on line 2. Use the ▲/▼ keys to scroll through the menu items. Scroll through the menu items until desired item is displayed.

NOTE: If “Enter Code” is flashing, the access code must be entered before you can enter the menu. Access code is found in Appendix C. Appendix C may have been removed from the manual for security reasons.

5. Press the **SELECT** key to access chosen item. The top line of display shows menu item selected, while the second line shows current item value.
6. Use the ▲/▼ keys to change item value.
7. Save the new value by pressing the **SELECT** key (pressing the **MENU** key exits out of menu function without saving data).
8. Press the **MENU** key to exit current menu, and return to main menu.
9. Press the **MENU** key again to return to normal instrument operation.

If more than one item is to be changed, skip steps 8 and 9 until all changes are complete. If more items in the same menu are to be changed, scroll to them after saving the data (step 7). If other menus need to be accessed, press the **MENU** key once to access list of menus. The instrument is now at step 2 of the keystroke sequence.

Programming Example

The following example demonstrates the keystroke sequence explained above. In this example the high alarm setpoint is changed from -0.002 inches H₂O to -0.003 inches H₂O.

- ① Unit is in normal operation scrolling room pressure, flows, etc... Pressure is shown in this case.
- ② Press the **MENU** key to gain access to the menus.

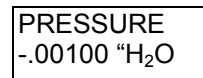

PRESSURE
-.00100 "H₂O



MENU

The first 2 menu choices are displayed.



SETPOINTS
ALARM

- 3 Press the ▼ key once. Blinking cursor should be on A of Alarm. Press the **SELECT** key to access the ALARM menu.



NOTE: Blinking cursor must be on A in Alarm.

Line 1 shows menu selected.
Line 2 shows first menu item.

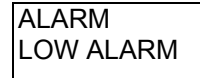

- 4 Press the ▼ key once. HIGH ALARM is shown on display.



Menu selected
Item name

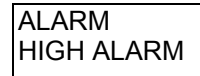

- 5 Press the **SELECT** key to access the high alarm setpoint. The item name (HIGH ALARM) is displayed on line 1, and the item's current value is displayed on line 2.



Item Name
Current Value

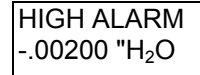

- 6 Press the ▼ key to change the high alarm setpoint to - 0.003 inches H₂O.

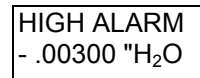

- 7 Press the **SELECT** key to save the new negative high alarm setpoint.



Three short beeps sound indicating that the data is being saved.

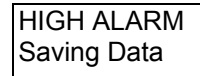

Immediately after the data is saved, the SUREFLOW returns to the menu level displaying the menu title on the top line of the display and the menu item on the bottom line (goes to step 4).

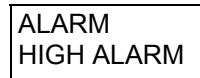

WARNING: If the **MENU** key was pressed instead of the **SELECT** key, the new data would not have been saved, and the SUREFLOW would have escaped back to the menu level shown in step 3.

- 8 Press the **MENU** key once to return to the menu level:

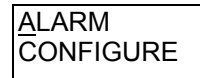

- ⑨ Press the **MENU** key a second time to return to the normal operating level:



Unit is now back in normal operation

PRESSURE
-.00100 "H₂O

Menu and Menu Items

The SUREFLOW is a very versatile device which can be configured to meet your specific application. This section describes all of the menu items available to program and change. Changing any item is accomplished by using the keypad, or if communications are installed through the RS-485 Communications port. If you are unfamiliar with the keystroke procedure, please see [Software Programming](#) for a detailed explanation. This section provides the following information:

- Complete list of menu and all menu items.
- Gives the menu or programming name.
- Defines each menu item's function; what it does, how it does it, etc.
- Gives the range of values that can be programmed.
- Gives default item value (how it shipped from factory).

The menus covered in this section are divided into groups of related items to ease programming. As an example all setpoints are in one menu, alarm information in another, etc. The manual follows the menus as programmed in the controller. The menu items are always grouped by menu and then listed in menu item order, not alphabetical order. Figure 5 shows a chart of all the Model 8681 controller menu items.

SETPOINTS

SETPOINT
 VENT MIN SET
 COOLING FLOW
 UNOCCUPY SET
 MAX SUP SET
 MIN EXH SET
 TEMP SETP
 UNOCC TEMP
 MIN OFFSET
 MAX OFFSET

ALARM

LOW ALARM
 HIGH ALARM
 MIN SUP ALM
 MAX EXH ALM
 ALARM RESET
 AUDIBLE ALM
 ALARM DELAY
 ALARM RELAY
 MUTE TIMEOUT

CONFIGURE

UNITS
 EXH CONFIG
 NET ADDRESS*
 MAC ADDRESS*
 ACCESS CODES

CALIBRATION

TEMP CAL
 SENSOR SPAN
 ELEVATION

CONTROL

SPEED
 SENSITIVITY
 SUP CONT DIR
 EXH CONT DIR
 Kc VALUE
 Ti VALUE
 Kc OFFSET
 REHEAT SIG
 TEMP DIR
 TEMP DB
 TEMP TR
 TEMP TI

SYSTEM FLOW

TOT SUP FLOW
 TOT EXH FLOW
 OFFSET VALUE
 SUP SETPOINT
 EXH SETPOINT

FLOW CHECK

SUP FLOW IN
 EXH FLOW IN
 HD1 FLOW IN
 HD2 FLOW IN**

DIAGNOSTICS

CONTROL SUP
 CONTROL EXH
 CONTROL TEMP
 SENSOR INPUT
 SENSOR STAT
 TEMP INPUT
 ALARM RELAY
 RESET TO DEF

SUPPLY FLOW

SUP DCT AREA
 SUP FLO ZERO
 SUP LO SETP
 SUP HI SETP
 SUP LOW CAL
 SUP HIGH CAL
 FLO STA TYPE
 TOP VELOCITY
 RESET CAL

EXHAUST FLOW

EXH DCT AREA
 EXH FLO ZERO
 EXH LO SETP
 EXH HI SETP
 EXH LOW CAL
 EXH HIGH CAL
 FLO STA TYPE
 TOP VELOCITY
 RESET CAL

HOOD FLOW

HD1 DCT AREA
 HD2 DCT AREA**
 HD1 FLO ZERO
 HD2 FLO ZERO**
 MIN HD1 FLOW
 MIN HD2 FLOW**
 HD1 LOW CAL
 HD1 HIGH CAL
 HD2 LOW CAL**
 HD2 HIGH CAL**
 FLO STA TYPE
 TOP VELOCITY
 RESET CAL

*MAC ADDRESS Menu Item only appears as a menu option for a Model 8681-BAC Adaptive Offset Controller which includes a BACnet MSTP board. The Menu Item NET ADDRESS is deleted as a menu option on the Model 8681-BAC.

**These menu items do not appear as options on the Model 8681-BAC.

Figure 5: Menu Items - Model 8681/8681-BAC Controller

SETPOINTS MENU

MENU ITEM	SOFTWARE NAME	ITEM DESCRIPTION	ITEM RANGE	DEFAULT VALUE
PRESSURE SETPOINT	SETPOINT	<p>The SETPOINT item sets the pressure control setpoint. The SUREFLOW controller maintains this setpoint, negative or positive, under normal operating conditions.</p> <p>Pressure differential is not maintained by direct pressure control; i.e. modulating dampers in response to pressure changes. The pressure signal is an AOC input that is used to calculate the required air flow offset value. The calculated offset value changes the supply (or exhaust) flow volume which changes the pressure differential. When the calculated offset value is between the MIN OFFSET and MAX OFFSET, room pressure control can be maintained. If the offset required to maintain pressure is less than the MIN OFFSET or greater the MAX OFFSET, pressure control will not be maintained.</p>	0 to -0.19500 "H ₂ O or 0 to +0.19500 H ₂ O	-0.00100" H₂O
VENTILATION MINIMUM SUPPLY FLOW SETPOINT	VENT MIN SET	<p>The VENT MIN SET item sets the ventilation supply airflow setpoint. This item provides a minimum supply airflow to meet the ventilation requirement, by preventing the supply flow from going below the preset minimum flow.</p> <p>The controller will not allow the supply air damper to be closed further than the VENT MIN SET setpoint. If room pressure is not maintained at minimum supply flow, the general exhaust damper modulates open until pressure setpoint is reached (provided offset is between MIN OFFSET and MAX OFFSET).</p>	0 to 30,000 CFM (0 to 14100 l/s) Linear based flow stations 0 to TOP VELOCITY times the duct area in square feet (ft ²): square meters (m ²).	0

SETPOINTS MENU *(continued)*

MENU ITEM	SOFTWARE NAME	ITEM DESCRIPTION	ITEM RANGE	DEFAULT VALUE
SPACE COOLING SUPPLY FLOW SETPOINT	COOLING FLOW	<p>The COOLING FLOW item sets the space cooling supply airflow setpoint. This item defines a supply air flow intended to meet the space's cooling requirements by allowing the supply flow to increase, gradually, to the COOLING FLOW setpoint, from a minimum ventilation rate, when the space temperature is too warm..</p> <p>If room pressure is not maintained at minimum temperature flow, the general exhaust damper modulates open until pressure setpoint is reached (provided offset is between MIN OFFSET and MAX OFFSET).</p> <p>WIRING: This item requires 1000Ω platinum RTD to be wired to the TEMPERATURE input (DIM pins 23 and 24). The temperature sensor toggles the AOC between VENT MIN SET and COOLING FLOW.</p>	<p>0 to 30,000 CFM (0 to 14100 l/s)</p> <p>Linear based flow stations 0 to TOP VELOCITY times the duct area in square feet (ft²): square meters (m²).</p>	0
UNOCCUPIED SUPPLY FLOW MINIMUM	UNOCCUPY SET	<p>The UNOCCUPY SET item sets a minimum supply flow setpoint when the laboratory is unoccupied (requires fewer air changes per hour). When UNOCCUPY SET is active, the VENT MIN SET and COOLING FLOW setpoints are turned off, since only one minimum supply setpoint can be enabled.</p> <p>The controller will not allow the supply air damper to be closed further than the UNOCCUPY SET setpoint. If room pressure is not maintained at minimum supply flow, the general exhaust damper modulates open until pressure setpoint is reached (provided required offset is between MIN OFFSET and MAX OFFSET).</p> <p>WIRING: This item is enabled through RS 485 communication sends commands. When the UNOCCUPY SET menu item is enabled, VENT MIN SET and COOLING FLOW are disabled. Disabling UNOCCUPY SET and enables VENT MIN SET and COOLING FLOW.</p>	<p>0 to 30,000 CFM (0 to 14100 l/s)</p> <p>Linear based flow stations 0 to TOP VELOCITY times the duct area in square feet (ft²): square meters (m²).</p>	0

SETPOINTS MENU *(continued)*

MENU ITEM	SOFTWARE NAME	ITEM DESCRIPTION	ITEM RANGE	DEFAULT VALUE
MAXIMUM SUPPLY FLOW SETPOINT	MAX SUP SET	The MAX SUP SET item sets the maximum supply air flow into the laboratory. The controller will not allow the supply air damper to open further than the MAX SUP SET flow setpoint. NOTE: The laboratory may not hold pressure setpoint when supply air is limited.	0 to 30,000 CFM (0 to 14100 l/s) Linear based flow stations 0 to TOP VELOCITY times the duct area in square feet (ft ²): square meters (m ²).	OFF
MINIMUM EXHAUST FLOW SETPOINT	MIN EXH SET	The MIN EXH SET item sets the minimum general exhaust air flow out of the laboratory. The controller will not allow the general exhaust air damper to close further than the MIN EXH SET flow setpoint. NOTE: This item requires a TSI compatible flow station and control damper to be mounted in the general exhaust duct.	0 to 30,000 CFM (0 to 14100 l/s) Linear based flow stations 0 to TOP VELOCITY times the duct area in square feet (ft ²): square meters (m ²).	OFF
SPACE TEMPERATURE SETPOINT	TEMP SETP	The TEMP SETP item sets the temperature setpoint of the space. The SUREFLOW controller maintains the temperature setpoint under normal operating conditions. WIRING: The 1000Ω platinum RTD temperature sensor is connected to the temp input (pins 23 & 24, DIM). The temperature sensor signal is continuously monitored by the AOC.	50°F to 85°F.	68°F

SETPOINTS MENU *(continued)*

MENU ITEM	SOFTWARE NAME	ITEM DESCRIPTION	ITEM RANGE	DEFAULT VALUE
UNOCCUPIED SPACE TEMPERATURE SETPOINT	UNOCC TEMP	The UNOCC TEMP item sets the temperature setpoint of the space during unoccupied mode. The SUREFLOW controller maintains the temperature setpoint under unoccupied operating conditions. WIRING: The 1000Ω platinum RTD temperature sensor is connected to the temp input (pins 23 & 24, DIM). The temperature sensor signal is continuously monitored by the AOC.	50°F to 85°F.	68°F
MINIMUM FLOW OFFSET	MIN OFFSET	The MIN OFFSET item sets the minimum air flow offset between total exhaust flow (fume hood, general exhaust, other exhaust) and total supply flow.	- 10,000 to 10,000 CFM	0
MAXIMUM FLOW OFFSET	MAX OFFSET	The MAX OFFSET item sets the maximum air flow offset between total exhaust flow (fume hood, general exhaust, other exhaust) and total supply flow.	- 10,000 to 10,000 CFM	0
	END OF MENU	The END OF MENU item informs you that the end of a menu has been reached. You can either scroll back up the menu to make changes, or press the SELECT or MENU key to exit out of the menu.		

ALARM MENU

MENU ITEM	SOFTWARE NAME	ITEM DESCRIPTION	ITEM RANGE	DEFAULT VALUE
LOW PRESSURE ALARM	LOW ALARM	The LOW ALARM item sets the low pressure alarm setpoint. A low alarm condition is defined as when the room pressure falls below or goes in the opposite direction of the LOW ALARM setpoint.	OFF 0 to -0.19500 "H ₂ O 0 to +0.19500 "H ₂ O	OFF
HIGH PRESSURE ALARM	HIGH ALARM	The HIGH ALARM item sets the high pressure alarm setpoint. A high alarm condition is defined as when the room pressure rises above the HIGH ALARM setpoint.	OFF 0 to -0.19500 "H ₂ O 0 to +0.19500 "H ₂ O	OFF
MINIMUM SUPPLY FLOW ALARM	MIN SUP ALM	The MIN SUP ALM item sets the supply flow alarm setpoint. A minimum flow alarm is defined as when the supply duct flow is less than the MIN SUP ALM setpoint. NOTE: Supply air duct size SUP DCT AREA (Supply Flow menu) must be entered before MIN SUP ALM can be accessed. Actual total supply air flow is found in TOT SUP FLOW menu item (system flow menu). WIRING: This item is disabled when the UNOCCUPY SET is enabled [AUX key is pressed, or the RS 485 communications sends a command].	0 to 30,000 CFM (0 to 14100 l/s) Linear based flow stations 0 to TOP VELOCITY times the supply duct area in square feet (ft ²): square meters (m ²).	OFF

ALARM MENU *(continued)*

SOFTWARE				DEFAULT
MENU ITEM	NAME	ITEM DESCRIPTION	ITEM RANGE	VALUE
MAXIMUM EXHAUST FLOW ALARM	MAX EXH ALM	The MAX EXH ALM item sets the general exhaust duct's flow alarm setpoint. A maximum flow alarm is defined as when the general exhaust duct flow is greater than the MAX EXH ALM setpoint. NOTE: General exhaust air duct size EXH DCT AREA (Exhaust Flow menu) must be entered before MAX EXH ALM can be accessed. Actual total exhaust air flow is found in TOT EXH FLOW menu item (system flow menu).	0 to 30,000 CFM (0 to 14100 l/s) Linear based flow stations 0 to TOP VELOCITY times the supply duct area in square feet (ft ²): square meters (m ²).	OFF
ALARM RESET	ALARM RESET	The ALARM RESET item selects how the alarms terminate after the unit returns to control setpoint (pressure or flow). UNLATCHED (alarm follow) automatically resets the alarms when the unit reaches control setpoint. LATCHED requires the staff to press the RESET key after the unit returns to control setpoint. The ALARM RESET affects the audible alarm, visual alarm, and relay output, which means all are latched or unlatched.	LATCHED OR UNLATCHED	UNLATCHED
AUDIBLE ALARM	AUDIBLE ALM	The AUDIBLE ALM item selects whether the audible alarm is turned ON or OFF. Selecting ON requires the staff to press the MUTE key to silence the audible alarm. Selecting OFF permanently mutes all audible alarms, except when the EMERGENCY key is pressed.	ON or OFF	ON
ALARM DELAY	ALARM DELAY	The ALARM DELAY determines the length of time the alarm is delayed after an alarm condition has been detected. This delay affects the visual alarm, audible alarm, and relay outputs. An ALARM DELAY prevents nuisance alarms from people entering and leaving the laboratory.	20 to 600 SECONDS	20 SECONDS

ALARM MENU *(continued)*

MENU ITEM	SOFTWARE NAME	ITEM DESCRIPTION	ITEM RANGE	DEFAULT VALUE
ALARM RELAY	ALARM RELAY	The ALARM RELAY item selects which alarms activate the relay contacts (pins 13, 14). Selecting PRESSURE triggers the relays when a pressure alarm is present. Selecting FLOW triggers the relays when a low flow condition exists. This item only affects the relay contacts, all audible and visual alarms are still active regardless of the ALARM RELAY status.	PRESSURE or FLOW	PRESSURE
<p>NOTE: Pins 13, 14 -Alarm relay contacts; configurable for pressure or flow alarms.</p>				
MUTE TIMEOUT	MUTE TIMEOUT	The MUTE TIMEOUT determines the length of time the audible alarm is silenced after the MUTE key is pressed. This delay temporarily mutes the audible alarm.	5 to 30 MINUTES	5 MINUTES
<p>NOTE: If the DIM is in alarm when MUTE TIMEOUT expires, the audible alarm turns on. When the pressure returns to the safe range, the MUTE TIMEOUT is canceled. If the room goes back into an alarm condition, the MUTE key must be pressed again to mute the audible alarm.</p>				
	END OF MENU	The END OF MENU item informs you that the end of a menu has been reached. You can either scroll back up the menu to make changes, or press the SELECT or MENU key to exit out of the menu.		

ALARM CONSTRAINTS

There are a number of constraints built into the software that prevent users from programming conflicting alarm information. These are as follows:

- The AOC does not allow the pressure alarms to be programmed within 20 ft/min (0.00028 in. H₂O at 0.001 in. H₂O) of the control setpoint.

Example: The control SETPOINT is set at -0.001 in. H₂O. The LOW ALARM setpoint cannot be set higher than -0.00072 in. H₂O. Conversely, the HIGH ALARM setpoint cannot be set lower than -0.00128 in. H₂O.
- The minimum flow alarms: MIN SUP ALM, MIN EXH ALM must be programmed to be at least 50 CFM less than the minimum flow setpoint.
- The pressure alarms: LOW ALARM, HIGH ALARM can be programmed for positive or negative pressure. However, both the low and high alarm must be set either positive or negative. The AOC does not allow one positive alarm and one negative alarm.
- Alarms do not terminate until the pressure or flow slightly exceeds alarm setpoint.
- The ALARM RESET item selects how the alarms terminates when controller returns to the safe range. The pressure and flow alarms all terminate the same; they are either latched or unlatched. If unlatched is selected, the alarms automatically turn off when the value slightly exceeds setpoint. If latched is selected, the alarms will not terminate until the controller returns to setpoint and the **RESET** key is pressed.
- There is a programmable ALARM DELAY that determines how long to delay before activating the alarms. This delay affects all pressure and flow alarms.
- The MUTE TIMEOUT item sets the length of time the audible alarm is off for all pressure and flow alarms.
- The display can only show one alarm message. Therefore, the controller has an alarm priority system, with the highest priority alarm being displayed. If multiple alarms exist, the lower priority alarms will not display until after the highest priority alarm has been eliminated. The alarm priority is as follows:
 - Pressure sensor - low alarm
 - Pressure sensor - high alarm
 - Low supply flow alarm
 - Low exhaust flow alarm
 - Data error
- The low and high pressure alarms are absolute values. The chart below shows how the values must be programmed in order to operate correctly.

-0.2 inches H ₂ O	0	+0.2 inches H ₂ O
(maximum negative)		(maximum positive)

High	Negative	Low	Zero	Low	Positive	High
Negative	Setpoint	Negative		Positive	Setpoint	Positive
Alarm		Alarm		Alarm		Alarm

The value of each setpoint or alarm is unimportant (except for small dead band) in graph above. It is important to understand that the negative (positive) low alarm must be between zero (0) pressure and the negative (positive) setpoint, and that the high alarm is a greater negative (positive) value than setpoint.

CONFIGURE MENU

MENU ITEM	SOFTWARE NAME	ITEM DESCRIPTION	ITEM RANGE	DEFAULT VALUE
DISPLAYED UNITS	UNITS	The UNITS item selects the unit of measure that the DIM displays all values (except calibration span). These units display for all menu items setpoints, alarms, flows, etc.	FT/MIN, m/s, in. H ₂ O, Pa	"H ₂ O"
GENERAL EXHAUST DUCT CONFIGURATION	EXH CONFIG	The EXH CONFIG menu item determines the exhaust configuration. If the general exhaust duct is separate from the total exhaust, select UNGANGED (left side of Figure 6). If the general exhaust duct is part of the total exhaust, select GANGED (right side of Figure 6). The correct configuration is required for the control algorithm to function correctly.	GANGED or UNGANGED	UNGANGED

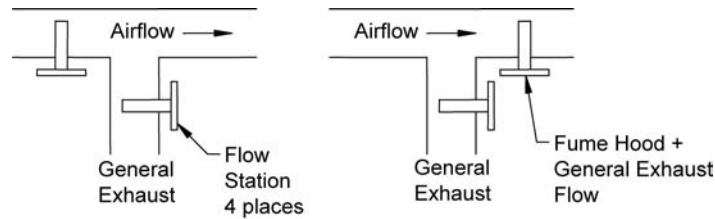

Figure 6: Exhaust Configuration

NOTE: The flow station input for a GANGED flow measurement is to be wired to the applicable fume hood flow input; either HD 1 INPUT (terminals 11 & 12) or the HD 2 INPUT (terminals 27 & 28).

NOTE: A GANGED flow measurement configuration still requires a separate General Exhaust flow measurement (right side of Figure 6).

CONFIGURE MENU *(continued)*

MENU ITEM	SOFTWARE NAME	ITEM DESCRIPTION	ITEM RANGE	DEFAULT VALUE
NETWORK ADDRESS**	NET ADDRESS	The NET ADDRESS item is used to select the main network address of the individual room pressure device. Each unit on the network must have its own unique address. The values range from 1-247. If RS-485 communications are being used, a unique NET ADDRESS must be entered into the unit. There is no priority between the RS-485 and keypad. The most recent signal by either RS-485 or keypad initiates a change. RS-485 communications allows you access to all menu items except calibration and control items. The RS-485 network can initiate a change at any time. NOTE: The Model 8681 network protocol is Modbus .	1 to 247	1
MAC Address**	MAC ADDRESS	The MAC ADDRESS assigns the device an address on the MS/TP BACnet network. This address must be unique for each device on the BACnet network.	1 to 127	1
MENU ACCESS CODES	ACCESS CODES	The ACCESS CODES item selects whether an access code (pass code) is required to enter the menu. The ACCESS CODES item prevents unauthorized access to a menu. If the ACCESS CODES is <u>ON</u> , a code is required before the menu can be entered. Conversely, if the ACCESS CODES is <u>OFF</u> , no code is required to enter the menu.	ON or OFF	OFF
	END OF MENU	The END OF MENU item informs you that the end of a menu has been reached. You can either scroll back up the menu to make changes, or press the SELECT or MENU key to exit out of the menu.		

**The MAC ADDRESS Menu Item replaces the Network Address Menu Item on SUREFLOW controllers provided with the BACnet MSTP board.

CALIBRATION MENU

MENU ITEM	SOFTWARE NAME	ITEM DESCRIPTION	ITEM RANGE	DEFAULT VALUE
TEMPERATURE CALIBRATION	TEMP CAL	The TEMP CAL is used to enter the actual space temperature. This adjustment offsets the temperature sensor curve.	50°F to 85°F	
SENSOR SPAN	SENSOR SPAN	The SENSOR SPAN item is used to match or calibrate the TSI pressure sensor (velocity sensors) to the average room pressure velocity as measured by a portable air velocity meter. NOTE: The pressure sensor is factory calibrated. No initial adjustment should be necessary.	NONE	0
ALTITUDE	ELEVATION	The ELEVATION item is used to enter the elevation of the building above sea level. This item has a range of 0-10,000 feet in 1,000 foot increments. The pressure value needs to be corrected due to changes in air density at different elevations.	0 to 10,000 feet above sea level	0
	END OF MENU	The END OF MENU item informs you that the end of a menu has been reached. You can either scroll back up the menu to make changes, or press the SELECT or MENU key to exit out of the menu.		

CONTROL MENU

MENU ITEM	SOFTWARE NAME	ITEM DESCRIPTION	ITEM RANGE	DEFAULT VALUE
SPEED	SPEED	The SPEED item is used to select the control output speed (supply and general exhaust). When this item is selected, a bar graph is shown on the display. There are 10 bars, each one representing 10% of speed. Starting from the right side (+ sign), 10 bars displayed indicates maximum speed. This is the fastest the controller will operate. 1 bar is the slowest the controller will operate. The more bars displayed, the faster the control output.	1 to 10 bars	5 bars
SENSITIVITY	SENSITIVITY	<p>The SENSITIVITY item is used to select the integral dead band. The integral dead band determines when the controller uses integral control (slow control), and when the controller enters PID control (fast control). When this item is selected, a bar graph is shown on the display.</p> <p>There are 10 bars total, with each one representing 50 CFM. Starting from the right side (+ sign), 10 bars displayed indicates no dead band so the controller is always in PID control mode. Each bar missing represents ± 50 CFM of integral dead band. The less bars displayed, the larger the integral dead band. For example, with 8 bars displayed (2 bars missing) and an offset of 500 CFM, the integral dead band is between 400 and 600 CFM. When the measured offset is within this range, integral or slow control is used. However, when the flow offset falls below 400 CFM or rises above 600 CFM, PID control is enabled until the unit returns within the dead band.</p> <p>The SENSITIVITY item has a unique feature that when zero bars are displayed, the unit never goes into PID control. The control output is always a slow control signal.</p> <p>WARNING: When SENSITIVITY is set for 10 bars, the system is always in PID control, which will probably cause an unstable system. It is recommended that SENSITIVITY be set at 9 bars or less.</p>	0 to 10 bars	5 bars

CONTROL MENU *(continued)*

MENU ITEM	SOFTWARE NAME	ITEM DESCRIPTION	ITEM RANGE	DEFAULT VALUE
SUPPLY DAMPER CONTROL SIGNAL DIRECTION	SUP CONT DIR	The SUP CONT DIR item determines the control signal's output direction. As an example, if the control system closes the supply damper instead of opening the damper, this option reverses the control signal to now open the damper.	DIRECT or REVERSE	DIRECT
EXHAUST DAMPER CONTROL SIGNAL DIRECTION	EXH CONT DIR	The EXH CONT DIR item determines the control signal's output direction. As an example, if the control system closes the exhaust damper instead of opening the damper, this option reverses the control signal to now open the damper.	DIRECT or REVERSE	DIRECT
FLOW TRACKING CONTROL Kc VALUE & Ti VALUE	Kc VALUE Ti VALUE	<p>WARNING: The Kc VALUE and Ti VALUE allow you to manually change the primary PID control loop variables. DO NOT CHANGE THESE VALUES UNLESS YOU HAVE A THOROUGH UNDERSTANDING OF PID CONTROL LOOPS. CONTACT TSI FOR ASSISTANCE PRIOR TO CHANGING ANY VALUES. Contact TSI for assistance in determining your control problem and for instructions on how to change a value. Incorrectly changing a value results in poor or nonexistent control.</p> <p>Suggestion: Before changing Kc or Ti, change the SPEED or adjust the SENSITIVITY to try to eliminate the problem.</p> <p>The Kc VALUE item changes the gain control coefficient of the primary control loop (flow tracking loop). When this item is entered, a value for Kc is indicated on the display. If the AOC is not controlling correctly, the Kc gain control coefficient may need adjusting. Decreasing Kc slows the control system down, which increases stability. Increasing Kc will increase the control system which may cause system instability.</p>	<p>Kc = 0 to 1000 Ti = 0 to 1000</p> <p>The range of values is very large. Poor control occurs if values are more than twice or less than 1/2 the default value.</p>	<p>Kc = 80 Ti = 200</p>

CONTROL MENU *(continued)*

MENU ITEM	SOFTWARE NAME	ITEM DESCRIPTION	ITEM RANGE	DEFAULT VALUE
FLOW TRACKING CONTROL Kc VALUE & Ti VALUE <i>(continued)</i>		The Ti VALUE item changes the integral control coefficient of the primary control loop (flow tracking loop). When this item is entered, a value for Ti is indicated on the display. If the AOC is not controlling correctly, the unit may have an inappropriate integral control coefficient. Increasing Ti slows the control system which increases stability. Decreasing Ti increases the control system speed which may cause system instability.		
ADAPTIVE OFFSET CONTROL Kc VALUE	Kc OFFSET	<p>WARNING: The Kc OFFSET sets the pressure control PID variable. DO NOT CHANGE THIS VALUE UNLESS YOU HAVE A THOROUGH UNDERSTANDING OF PID CONTROL LOOPS. CONTACT TSI FOR ASSISTANCE PRIOR TO CHANGING ANY VALUES. Contact TSI for assistance in determining your control problem and for instructions on how to change a value. Incorrectly changing a value results in poor or nonexistent control.</p> <p>The Kc OFFSET item changes the gain control coefficient of the secondary control loop (pressure control loop). The pressure control loop is very slow when compared to the primary flow control loop. This menu item should not be changed unless problems with the pressure control loop can be established (confirm problem is not with primary flow control loop).</p> <p>When this item is entered, a value for Kc is indicated on the display. Decreasing Kc slows the pressure control loop down, while increasing Kc increases the pressure control loop speed.</p>	Kc = 0 to 1000 The range of values is very large. Poor control occurs if values are more than twice or less than 1/2 the default value.	Kc = 200
TEMPERATURE OUTPUT SIGNAL	REHEAT SIG	The REHEAT SIG item switches the supply and exhaust control outputs from 0 to 10 VDC to 4 to 20 mA.	0 to 10 VDC or 4 to 20 mA	0 to 10 VDC

CONTROL MENU *(continued)*

MENU ITEM	SOFTWARE NAME	ITEM DESCRIPTION	ITEM RANGE	DEFAULT VALUE
TEMPERATURE CONTROL DIRECTION	TEMP DIR	The TEMP DIR item determines the control signal's output direction. As an example: If the control system closes the reheat valve instead of opening this valve, this option reverses the control signal to now open the valve.	DIRECT OR REVERSE	DIRECT
TEMPERATURE SETPOINT DEAD BAND	TEMP DB	The TEMP DB item determines the controller's temperature control deadband, which is defined as the temperature range above <u>and</u> below the temperature setpoint (TEMP SETP or UNOCC TEMP), where the controller will not take corrective action.	0.0°F to ±1.0°F	±0.1°F

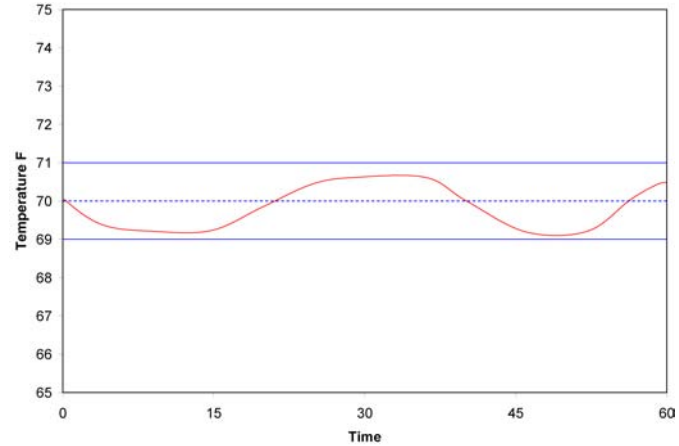

If TEMP DB is set to 1.0°F, and the TEMP SETP is set to 70.0°F, the controller will not take corrective action unless the space temperature is below 69.0°F or above 71.0°F.

CONTROL MENU *(continued)*

MENU ITEM	SOFTWARE NAME	ITEM DESCRIPTION	ITEM RANGE	DEFAULT VALUE
TEMPERATURE SETPOINT THROTTLING RANGE	TEMP TR	The TEMP TR item determines the controller's temperature control throttling range, which is defined as the temperature range for the controller to fully open and fully close the reheat valve.	$\pm 2.0^{\circ}\text{F}$ to $\pm 20.0^{\circ}\text{F}$	$\pm 3.0^{\circ}\text{F}$

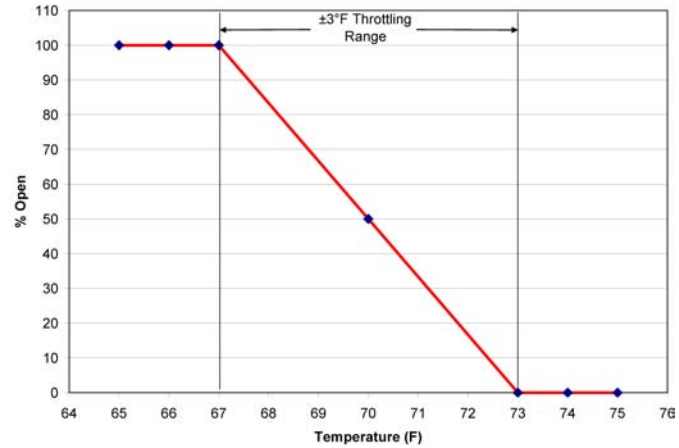

If TEMP TR is set to $\pm 3.0^{\circ}\text{F}$, and the TEMP SETP is set to 70.0°F , the reheat valve will be fully open when the space temperature is 67°F . Similarly, the reheat valve will be fully closed when the space temperature is 73.0°F .

CONTROL MENU *(continued)*

MENU ITEM	SOFTWARE NAME	ITEM DESCRIPTION	ITEM RANGE	DEFAULT VALUE
TEMPERATURE SETPONT INTEGRAL VALUE	TEMP TI	WARNING: The TEMP TI item provides you with the ability to manually change the temperature control PI integral control loop variable. DO NOT CHANGE THIS VALUE UNLESS YOU HAVE A THOROUGH UNDERSTANDING OF PI CONTROL LOOPS. CONTACT TSI FOR ASSISTANCE PRIOR TO CHANGING ANY VALUES. Contact TSI for assistance in determining your control problem and for instructions on how to change a value. Incorrectly changing a value results in poor or nonexistent control.	1 to 10000 sec	2400 sec
	END OF MENU	The END OF MENU item informs you that the end of a menu has been reached. You can either scroll back up the menu to make changes, or press the SELECT or MENU key to exit out of the menu.		

Suggestion: Before changing TEMP TI adjust the TEMP DB or adjust the TEMP TR to try to eliminate the problem.

The TEMP TI item is used to read and change the integral control coefficient. When this item is entered, a value for TEMP TI is indicated on the display. If the SUREFLOW is not controlling correctly, the unit may have an inappropriate integral control coefficient. Increasing TEMP TI slows the control system which increases stability. Decreasing TEMP TI speeds up the control system which may cause system instability.

SYSTEM FLOW MENU

MENU ITEM	SOFTWARE NAME	ITEM DESCRIPTION	ITEM RANGE	DEFAULT VALUE
TOTAL SUPPLY AIR FLOW	TOT SUP FLOW	The TOT SUP FLOW menu item displays the current total measured supply flow into the laboratory. This is a system information only menu item; no programming is possible.	NONE: Read only value	NONE
TOTAL EXHAUST AIR FLOW	TOT EXH FLOW	The TOT EXH FLOW menu item displays the current total measured exhaust flow out of the laboratory. This item calculates total exhaust by summing EXH FLOW IN and HD1 FLOW IN and HD2 FLOW IN. This is a system information only menu item; no programming is possible.	NONE: Read only value	NONE
CONTROL OFFSET VALUE	OFFSET VALUE	The OFFSET VALUE menu item displays the actual flow offset being used to control the laboratory. The OFFSET VALUE is calculated by the AOC control algorithm, which uses the MIN OFFSET, MAX OFFSET, and SETPOINT items to calculate required offset. This is a system information only menu item; no programming is possible.	NONE: Read only value	NONE
SUPPLY FLOW SETPOINT (CALCULATED)	SUP SETPOINT	The SUP SETPOINT menu item displays the supply flow setpoint, which is calculated by the AOC control algorithm. The calculated SUP SETPOINT is a diagnostic item used to compare the actual TOT SUP FLOW to the calculated flow (they should match within 10%). This is a system information only menu item; no programming is possible.	NONE: Read only value	NONE

SYSTEM FLOW MENU *(continued)*

MENU ITEM	SOFTWARE NAME	ITEM DESCRIPTION	ITEM RANGE	DEFAULT VALUE
GENERAL EXHAUST FLOW SETPOINT (CALCULATED)	EXH SETPOINT	The EXH SETPOINT menu item displays the general exhaust flow setpoint, which is calculated by the AOC control algorithm. The calculated EXH SETPOINT is a diagnostic item used to compare the actual EXH FLOW IN (from FLOW CHECK MENU) to the calculated flow. This is a system information only menu item: no programming is possible.	NONE: Read only value	NONE
	END OF MENU	The END OF MENU item informs you that the end of a menu has been reached. You can either scroll back up the menu to make changes, or press the SELECT or MENU key to exit out of the menu.		

FLOW CHECK MENU

MENU ITEM	SOFTWARE NAME	ITEM DESCRIPTION	ITEM RANGE	DEFAULT VALUE
SUPPLY AIR FLOW	SUP FLOW IN	<p>The SUP FLOW IN menu item displays the current supply air flow. This item is a diagnostics tool used to compare the supply flow to a traverse of the duct work. If flow error is greater than 10%, calibrate flow station.</p> <p>When a volt meter is hooked to the flow station output, a voltage should be displayed. The exact voltage displayed is relatively unimportant. It is more important that the voltage is changing which indicates the flow station is working correctly.</p>	NONE: Read only value	NONE
GENERAL EXHAUST FLOW	EXH FLOW IN	<p>The EXH FLOW IN menu item displays the current exhaust flow from a general exhaust. This item is a diagnostics tool used to compare the general exhaust flow to a traverse of the duct work. If flow error is greater than 10%, calibrate flow station.</p> <p>When a volt meter is hooked to the flow station output, a voltage should be displayed. The exact voltage displayed is relatively unimportant. It is more important that the voltage is changing which indicates the flow station is working correctly.</p>	NONE: Read only value	NONE
FUME HOOD EXHAUST FLOW	HD1 FLOW IN HD2 FLOW IN*	<p>The HD# FLOW IN menu item displays the current exhaust flow from a fume hood. This item is a diagnostics tool to compare the hood flow reading to a traverse of the duct work. If flow reading and traverse match within 10%, no change is needed. If flow error is greater than 10%, calibrate flow station.</p> <p>When a volt meter is hooked to the flow station output, a voltage should be displayed. The exact voltage displayed is relatively unimportant. It is more important that the voltage is changing which indicates the flow station is working correctly.</p>	NONE: Read only value	NONE
	END OF MENU	<p>The END OF MENU item informs you that the end of a menu has been reached. You can either scroll back up the menu to make changes, or press the SELECT or MENU key to exit out of the menu.</p>		

*These menu items do not appear on SUREFLOW controllers with BACnet communications.

DIAGNOSTICS MENU

MENU ITEM	SOFTWARE NAME	ITEM DESCRIPTION
SUPPLY AIR CONTROL OUTPUT	CONTROL SUP	<p>The CONTROL SUP item manually changes the control output signal to the supply air actuator/damper (or motor speed drive). When this item is entered, a number between 0 and 100% is shown on the display indicating the control output value. Pressing the ▲/▼ keys change the count on the display. Pressing the ▲ key increases the displayed value, while pressing the ▼ key decreases the displayed value. The supply air damper or VAV box should change (modulate) as the number changes. A count of 50% should position the damper approximately 1/2 open. On units controlling variable frequency drives, fan speed should increase or decrease as numbers change.</p> <p>WARNING: The CONTROL SUP function overrides the AOC control signal. Adequate room pressure will NOT be maintained while in this item.</p>
EXHAUST AIR CONTROL OUTPUT	CONTROL EXH	<p>The CONTROL EXH item manually changes the control output signal to the exhaust air actuator/damper (or motor speed drive). When this item is entered, a number between 0 and 100% is shown on the display indicating the control output value. Pressing the ▲/▼ keys changes the count on the display. Pressing the ▲ key increases the displayed value, while pressing the ▼ key decreases the displayed value. The exhaust air damper or VAV box should change (modulate) as the number changes. A count of 50% should position the damper approximately 1/2 open. On units controlling variable frequency drives, fan speed should increase or decrease as numbers change.</p> <p>WARNING: The CONTROL EXH function overrides the AOC control signal. Adequate room pressure will NOT be maintained while in this item.</p>
REHEAT VAVLE CONTROL OUTPUT	CONTROL TEMP	<p>The CONTROL TEMP item manually changes the control output signal to the reheat valve. When this item is entered, a number between 0 and 100% is shown on the display indicating the control output value. Pressing the ▲/▼ keys changes the count on the display. Pressing the ▲ key increases the displayed value, while pressing the ▼ key decreases the displayed value. The reheat control valve should modulate as the number changes. A count of 50% should position the valve approximately 1/2 open.</p> <p>WARNING: The CONTROL TEMP function overrides the AOC control signal. Adequate space temperature will NOT be maintained while in this item.</p>

DIAGNOSTICS MENU *(continued)*

MENU ITEM	SOFTWARE NAME	ITEM DESCRIPTION
PRESSURE SENSOR SIGNAL CHECK	SENSOR INPUT	The SENSOR INPUT item verifies that the DIM is receiving a signal from the pressure sensor. When this item is entered, a voltage is indicated on the display. The exact voltage displayed is relatively unimportant. It is more important that the voltage is changing which indicates the sensor is working correctly. 0 volts represents a negative pressure of -0.2 inches H ₂ O. 5 volts represents 0 pressure 10 volts represents a positive pressure of +0.2 inches H ₂ O.
PRESSURE SENSOR COMMUNICATION CHECK	SENSOR STAT	The SENSOR STAT item verifies that the RS-485 communications between the pressure sensor and DIM is working correctly. Pressure sensor error messages do not display on DIM except when SENSOR STAT item is selected. This item displays NORMAL if communications are established correctly. If problems exist, one of four error messages display: COMM ERROR - DIM cannot communicate with sensor. Check all wiring and pressure sensor address. Address must be 1. SENS ERROR - Problem with sensor bridge. Physical damage to pressure sensor or sensor circuitry. Unit is not field repairable. Send to TSI for repair. CAL ERROR - Calibration data lost. Sensor must be returned to TSI to be calibrated. DATA ERROR - Problem with EEPROM, field calibration, or analog output calibration lost. Check all data programmed and confirm unit is function correctly.
TEMPERATURE INPUT	TEMP INPUT	The TEMP INPUT item reads the input from the temperature sensor. When this item is entered, a temperature is indicated on the display. The exact temperature displayed is relatively unimportant. It is more important that the temperature changes indicating the temperature sensor is working correctly. The output range that can be read is resistance.
RELAY OUTPUT	ALARM RELAY	The relay menu items are used to change the state of the relay contact. When entered, the display indicates either OPEN or CLOSED . The ▲/▼ keys are used to toggle the state of the relay. Pressing the ▲ key will OPEN the alarm contact. Pressing the ▼ key will CLOSE the alarm contact. When the contact is closed, the relay is in an alarm condition.

DIAGNOSTICS MENU *(continued)*

MENU ITEM	SOFTWARE NAME	ITEM DESCRIPTION
RESET THE CONTROLLER TO FACTORY DEFAULT SETTINGS	RESET TO DEF	<p>When this menu item is entered, the 8681 prompts you to verify that you want to do this by indicating NO. Use the ▲ keys change the display to YES then press the SELECT key to reset the controller to its factory defaults. Pressing the MENU key before the SELECT key exits out of the menu item.</p> <p>WARNING: If YES is selected, the Model 8681 resets all menu items to their factory default settings: The controller will have to be reprogrammed and recalibrated after this operation is completed.</p>
	END OF MENU	The END OF MENU item informs you that the end of a menu has been reached. You can either scroll back up the menu to make changes, or press the SELECT or MENU key to exit out of the menu.

SUPPLY FLOW MENU

MENU ITEM	SOFTWARE NAME	ITEM DESCRIPTION	ITEM RANGE	DEFAULT VALUE
SUPPLY AIR DUCT SIZE	SUP DCT AREA	<p>The SUP DCT AREA item inputs the supply air exhaust duct size. The duct size is needed to compute the supply air flow into the laboratory. This item requires a flow station to be mounted in each supply duct.</p> <p>If the DIM displays English units, area must be entered in square feet. If metric units are displayed area must be entered in square meters.</p>	<p>0 to 10 square feet (0 to 0.9500 square meters)</p> <p>The DIM does not compute duct area. The area must be first calculated and then entered into the unit.</p>	0
SUPPLY FLOW STATION ZERO	SUP FLO ZERO	<p>The SUP FLO ZERO item establishes the flow station zero flow point. A zero or no flow point needs to be established in order to obtain a correct flow measurement output (see Calibration section).</p> <p>All <u>pressure</u> based flow stations need to have a SUP FLO ZERO established on initial set up. <u>Linear</u> flow stations with a minimum output of 0 VDC do not need a SUP FLO ZERO.</p>	NONE	
SUPPLY FLOW LOW CALIBRATION SETTING	SUP LOW SETP	The SUP LOW SETP menu item sets the supply damper position for supply low flow calibration.	0 to 100% OPEN	0% OPEN

SUPPLY FLOW MENU *(continued)*

MENU ITEM	SOFTWARE NAME	ITEM DESCRIPTION	ITEM RANGE	DEFAULT VALUE
SUPPLY FLOW HIGH CALIBRATION SETTING	SUP HIGH SETP	The SUP HIGH SETP menu item sets the supply damper position for the supply high flow calibration.	0 to 100% OPEN	100% OPEN
SUPPLY FLOW LOW CALIBRATION	SUP LOW CAL	The SUP LOW CAL menu items display the currently measured supply flow rate and the calibrated value for that supply flow. The supply dampers move to the SUP LOW SETP damper position for the low calibration. The calibrated supply flow can be adjusted using the ▲/▼ keys to make it match a reference measurement. Pressing the SELECT key saves the new calibration data.		
SUPPLY FLOW HIGH CALIBRATION	SUP HIGH CAL	The SUP HIGH CAL menu items display the currently measured supply flow rate and the calibrated value for that supply flow. The supply dampers move to the SP HIGH SETP damper position for the high calibration. The calibrated supply flow can be adjusted using the ▲/▼ keys to make it match a reference measurement. Pressing the SELECT key saves the new calibration data.		
FLOW STATION TYPE	FLO STA TYPE	The FLO STA TYPE item is used to select the flow station input signal. PRESSURE is selected when TSI flow stations with pressure transducers are installed. LINEAR is selected when a linear output flow station is installed. Typically a thermal anemometer based flow station.	PRESSURE or LINEAR	PRESSURE
MAXIMUM FLOW STATION VELOCITY	TOP VELOCITY	The TOP VELOCITY item is used to input the maximum velocity of a <u>linear</u> flow station output. A TOP VELOCITY must be input for the linear flow station to operate. NOTE: This item is disabled if a pressure based flow station is installed.	0 to 5,000 FT/MIN (0 to 25.4 m/s)	0

SUPPLY FLOW MENU *(continued)*

MENU ITEM	SOFTWARE NAME	ITEM DESCRIPTION	ITEM RANGE	DEFAULT VALUE
RESET CALIBRATION	RESET CAL	The RESET CAL menu item zeroes out the calibration adjustments for the supply flow. When this menu item is entered, the 8681 prompts you to verify that you want to do this. Press the SELECT key to reset the calibrations, and the MENU key to reject it.		
	END OF MENU	The END OF MENU item informs you that the end of a menu has been reached. You can either scroll back up the menu to make changes, or press the SELECT or MENU key to exit out of the menu.		

EXHAUST FLOW MENU

MENU ITEM	SOFTWARE NAME	ITEM DESCRIPTION	ITEM RANGE	DEFAULT VALUE
GENERAL EXHAUST DUCT SIZE	EXH DCT AREA	<p>The EXH DCT AREA item inputs the general exhaust duct size. The duct size is needed to compute the total general exhaust flow out of the laboratory. This item requires a flow station to be mounted in each general exhaust duct.</p> <p>If the DIM displays English units, area must be entered in square feet. If metric units are displayed area must be entered in square meters.</p>	<p>0 to 10 square feet (0 to 0.9500 square meters)</p> <p>The DIM does not compute duct area. The area must be first calculated and then entered into the unit.</p>	0
EXHAUST FLOW STATION ZERO	EXH FLO ZERO	<p>The EXH FLO ZERO item establishes the flow station zero flow point. A zero or no flow point needs to be established in order to obtain a correct flow measurement output (see Calibration section).</p> <p>All <u>pressure</u> based flow stations need to have an EXH FLO ZERO established on initial set up. <u>Linear</u> flow stations with a minimum output of 0 VDC do not need a SUP FLO ZERO.</p>	NONE	
EXHAUST FLOW LOW CALIBRATION SETTING	EXH LOW SETP	The EXH LOW SETP menu item sets the general exhaust damper position for general exhaust low flow calibration.	0 to 100% OPEN	0% OPEN
EXHAUST FLOW HIGH CALIBRATION SETTING	EXH HIGH SETP	The EXH HIGH SETP menu item sets the general exhaust damper position for the general exhaust high flow calibration.	0 to 100%	100% OPEN

EXHAUST FLOW MENU *(continued)*

MENU ITEM	SOFTWARE NAME	ITEM DESCRIPTION	ITEM RANGE	DEFAULT VALUE
EXHAUST FLOW LOW CALIBRATION	EXH LOW CAL	The EXH LOW CAL menu items display the currently measured general exhaust flow rate and the calibrated value for that general exhaust flow. The exhaust dampers move to the EXH LOW SETP damper position for the low calibration. The calibrated general exhaust can be adjusted using the ▲/▼ keys to make it match a reference measurement. Pressing the SELECT key saves the new calibration data.		
EXHAUST FLOW HIGH CALIBRATION	EXH HIGH CAL	The EXH HIGH CAL menu items display the currently measured general exhaust flow rate and the calibrated value for that general exhaust flow. The exhaust dampers moves to the EXH HIGH SETP damper position for the high calibration. The calibrated general exhaust flow can be adjusted using the ▲/▼ keys to make it match a reference measurement. Pressing the SELECT key saves the new calibration data.		
FLOW STATION TYPE	FLO STA TYPE	The FLO STA TYPE item is used to select the flow station input signal. PRESSURE is selected when TSI flow stations with pressure transducers are installed. LINEAR is selected when a linear output flow station is installed (0-5 VDC or 0-10 VDC): Typically a thermal anemometer based flow station.	PRESSURE or LINEAR	PRESSURE
MAXIMUM FLOW STATION VELOCITY	TOP VELOCITY	The TOP VELOCITY item is used to input the maximum velocity of a <u>linear</u> flow station output. A TOP VELOCITY must be input for the linear flow station to operate. NOTE: This item is disabled if a pressure based flow station is installed.	0 to 5,000 FT/MIN (0 to 25.4 m/s)	0
RESET CALIBRATION	RESET CAL	The RESET CAL menu item zeroes out the calibration adjustments for the general exhaust flow. When this menu item is entered, the 8681 prompts you to verify that you want to do this. Press the SELECT key to reset the calibrations, and the MENU key to reject it.		

EXHAUST FLOW MENU *(continued)*

MENU ITEM	SOFTWARE NAME	ITEM DESCRIPTION	ITEM RANGE	DEFAULT VALUE
	END OF MENU	The END OF MENU item informs you that the end of a menu has been reached. You can either scroll back up the menu to make changes, or press the SELECT or MENU key to exit out of the menu.		

HOOD FLOW MENU

MENU ITEM	SOFTWARE NAME	ITEM DESCRIPTION	ITEM RANGE	DEFAULT VALUE
FUME HOOD EXHAUST DUCT SIZE	HD1 DCT AREA <i>and</i> HD2 DCT AREA*	The HD# DCT AREA item inputs the fume hood exhaust duct size. The duct size is needed to compute the flow out of the fume hood. This item requires a flow station to be mounted in each fume hood exhaust duct. If the DIM displays English units, area must be entered in square feet. If metric units are displayed area must be entered in square meters.	0 to 10 square feet (0 to 0.9500 square meters)	0
FUME HOOD FLOW STATION ZERO	HD1 FLO ZERO <i>and</i> HD2 FLOW ZERO*	The HD# FLO ZERO item establishes the flow station zero flow point. A zero or no flow point needs to be established in order to obtain a correct flow measurement output (see Calibration section). All <u>pressure</u> based flow stations need to have a HD# FLO ZERO established on initial set up. <u>Linear</u> flow stations with a minimum output of 0-5 VDC do not need a HD# FLO ZERO.	NONE	
MINIMUM HOOD # FLOWS	MIN HD1 FLOW <i>and</i> MIN HD2 FLOW*	The MIN HD# FLOW menu items adjust the minimum flow value for each fume hood input. Use this menu item if the fume hood flow measurements are too low when the sash is closed.		
HOOD # LOW CALIBRATION POINTS	HD1 LOW CAL <i>and</i> HD2 LOW CAL*	The HD# LOW CAL menu items display the currently measured fume hood flow rate and the calibrated value for that fume hood flow. The calibrated hood flow can be adjusted using the ▲/▼ keys to make it match a reference measurement. Pressing the SELECT key saves the new calibration data.		

*These menu items do not appear on SUREFLOW controllers provided with BACnet communications.

HOOD FLOW MENU *(continued)*

MENU ITEM	SOFTWARE NAME	ITEM DESCRIPTION	ITEM RANGE	DEFAULT VALUE
HOOD # HIGH CALIBRATION POINTS	HD1 HIGH CAL <i>and</i> HD2 HIGH CAL*	The HD# HIGH CAL menu items display the currently measured fume hood flow rate and the calibrated value for that fume hood flow. The calibrated hood flow can be adjusted using the ▲/▼ keys to make it match a reference measurement. Pressing the SELECT key saves the new calibration data.		
FLOW STATION TYPE	FLO STA TYPE	The FLO STA TYPE item is used to select the flow station input signal. PRESSURE is selected when TSI flow stations with pressure transducers are installed. LINEAR is selected when a linear output flow station is installed (0-5 VDC or 0-10 VDC): Typically a thermal anemometer based flow station.	PRESSURE or LINEAR	PRESSURE
MAXIMUM FLOW STATION VELOCITY	TOP VELOCITY	The TOP VELOCITY item is used to input the maximum velocity of a <u>linear</u> flow station output. A TOP VELOCITY must be input for the linear flow station to operate. NOTE: This item is disabled if a pressure based flow station is installed.	0 to 5,000 FT/MIN (0 to 25.4 m/s)	0
RESET CALIBRATION	RESET CAL	The RESET CAL menu item zeroes out the calibration adjustments for the hood flow. When this menu item is entered, the 8681 prompts you to verify that you want to do this. Press the SELECT key to reset the calibrations and the MENU key to reject it.		
	END OF MENU	The END OF MENU item informs you that the end of a menu has been reached. You can either scroll back up the menu to make changes, or press the SELECT or MENU key to exit out of the menu.		

*These menu items do not appear on SUREFLOW controllers provided with BACnet communications.

Setup / Checkout

The AOC is easy to program and setup. This section covers the theory of operation, required software programming, a programming example, and how to verify (checkout) that the components are functioning correctly. The AOC uses a unique control sequence that combines flow and pressure differential measurements to maintain air balance and laboratory pressure, while interfacing with a thermostat to maintain laboratory temperature. The overall AOC control sequence seems quite complicated initially, but the [Theory of Operation](#) section breaks the sequence down into sub-sequences which simplifies the total system.

Theory of Operation

The AOC control system requires the following measurement inputs to function correctly:

- General exhaust flow measured with a flow station (if general exhaust is installed).
- Fume hood exhaust flow measured with a flow station.
- Supply air flow measured with a flow station.
- Temperature measured with a thermostat (if temperature is incorporated into sequence).
- Pressure differential with a TSI pressure sensor (if pressure is incorporated into sequence).

Laboratory air balance

Laboratory air balance is maintained by measuring the fume hood exhaust (or other exhaust), subtracting an offset flow from the fume hood total, and then setting the supply air damper(s) to maintain the offset between supply air and fume hood exhaust. The general exhaust damper is normally closed, except when room pressure cannot be maintained. This may occur when the fume hood sashes are all down and the supply air is at a minimum position. The general exhaust damper opens to maintain the required offset and pressure differential.

Pressure control

The pressure differential signal is sent to the AOC (assumption: laboratory is under negative pressure). If pressure is at setpoint, the control algorithm does nothing. If pressure is not at setpoint, the offset value is changed until pressure is maintained, or the minimum or maximum offset value is reached. If the offset value:

increases, the supply air is reduced until one of three events occur:

- Pressure setpoint is reached. The AOC maintains the new offset.
- The offset range is exceeded. The offset will be at maximum attempting to reach pressure setpoint. An alarm triggers to inform you pressure differential is not being maintained.
- Supply air minimum is reached. The general exhaust begins to open (was closed) to maintain pressure differential.

decreases, the supply air increases until one of three events occur:

- Pressure setpoint is reached. The AOC maintains the new offset.
- The offset range is exceeded. The offset will be at minimum attempting to reach pressure setpoint. An alarm triggers to inform you pressure differential is not being maintained.
- Supply air maximum is reached. The alarm triggers to inform you pressure differential is not being maintained.

NOTE: The pressure differential is a slow secondary control loop. The system initially starts with a calculated offset value and then slowly adjusts the offset value to maintain pressure differential.

Temperature control

The Model 8681 receives a temperature input from a temperature sensor (1000 Ω Platinum RTD). The Model 8681 controller maintains temperature control by:

- (1) Controlling supply and general exhaust for ventilation and cooling
- (2) Controlling the reheat coil for heating

The Model 8681 has three supply flow minimum setpoints. The ventilation setpoint (VENT MIN SET) is the minimum flow volume required to meet ventilation needs of the laboratory (ACPH). The temperature supply setpoint (COOLING FLOW) is the theoretical minimum flow required to meet cooling flow needs of the laboratory. The unoccupied setpoint (UNOCC SETP) is the minimum flow required when the lab is not occupied. All of these setpoints are configurable. If the Model 8681 is in the Unoccupied Mode, the controller will control the supply air flow to the UNOCCUPY SET ventilation rate, the supply flow will not be modulated for space cooling; space temperature control will be maintained by modulating the reheat coil.

The Model 8681 continuously compares the temperature setpoint to the actual space temperature. If setpoint is being maintained, no changes are made. If setpoint is not being maintained, and the space temperature is rising, the controller will first modulate the reheat valve closed. Once the reheat valve is fully closed the controller begins a 3-minute time period. If, after the 3-minute time period the reheat valve is still fully closed, the Model 8681 then gradually begins increasing the supply volume by 1 CFM/second up to the COOLING FLOW setpoint.

The controller, when controlling supply flow for cooling, will not increase the supply flow above the COOLING FLOW ventilation rate. If the space temperature decreases below the setpoint, the controller first reduces the supply volume. Once the supply volume reaches its minimum (VENT MIN SET), the controller then starts a 3-minute time period. If, after 3 minutes the supply flow is still at the VENT MIN SET flow rate, the controller begins modulating the reheat coil open to meet the heating demand.

If the general exhaust is in the closed position and fume hood loads require additional replacement air, the Model 8681 overrides ventilation or temperature setpoints to modulate supply for pressurization control. Temperature is then controlled by the reheat valve in this sequence.

The control output items in the DIAGNOSTICS menu shows a percentage value. If control direction for a given output is set to DIRECT, the diagnostic value will be percent OPEN. If control direction for a given output is set to REVERSE, the diagnostic value will be percent CLOSED.

NOTE: The greatest flow requirement dominates the supply flow. If hood replacement air exceeds the ventilation or temperature flow minimums, the replacement air requirement is maintained (minimums are ignored).

In summary, understanding the AOC control algorithm is the key to getting the system functioning correctly. The AOC control algorithm functions as follows:

SUPPLY AIR	=	GENERAL EXHAUST	+	FUME HOOD EXHAUST	-	OFFSET
Supply air is at minimum position; unless additional replacement air is required (fume hood or general exhaust).		General exhaust is closed or at minimum position; except when supply air is at minimum position and pressure control cannot be maintained.		Independent control loop by fume hood controller maintains face velocity. Hood exhaust flow is <u>monitored</u> by AOC. The AOC does not control the fume hood.		Programmed by user. User programs minimum and maximum offset.

Required Software Programming

The following menu items must be programmed for the AOC to function. See [Menu and Menu Items](#) section for information in individual menu items.

SUPPLY FLOW MENU	EXHAUST FLOW MENU	HOOD FLOW MENU	SETPOINT MENU
SUP DCT AREA	EXH DCT AREA	HD1 DCT AREA	MIN OFFSET
SUP FLO ZERO	EXH FLO ZERO	HD2 DCT AREA	MAX OFFSET
FLO STA TYPE	FLO STA TYPE	HD1 FLO ZERO	
TOP VELOCITY	TOP VELOCITY	HD2 FLO ZERO	
SUP LOW SETP	EXH LOW SETP	FLO STA TYPE	
SUP HIGH SETP	EXH HIGH SETP	TOP VELOCITY	
SUP LOW CAL	EXH LOW CAL	HD1 LOW CAL	
SUP HIGH CAL	EXH HIGH CAL	HD1 HIGH CAL	
		HD2 LOW CAL	
		HD2 HIGH CAL	

NOTE: If temperature or pressure control is being maintained by the AOC, the following menu items must also be programmed:

- **Temperature** - The temperature cooling and heating values: VENT MIN SET, TEMP MIN SET, and TEMP SETP.

- **Pressure** - The pressure differential value: SETPOINT

There are additional programmable software menu items to tailor the controller to your specific application or increase flexibility. These menu items are not required to be programmed for the AOC to operate.

Programming Example

The laboratory shown in Figure 7 is being initially setup. The required HVAC information is below the figure.

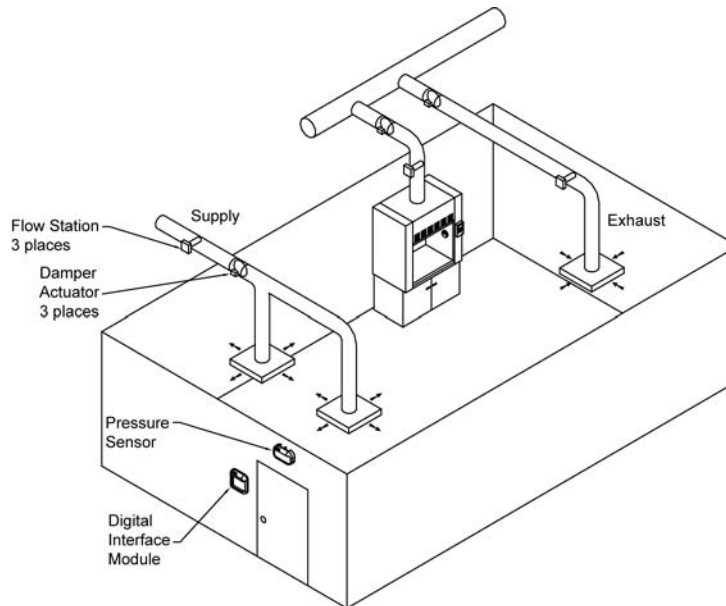

Figure 7: Laboratory Setup Example

Laboratory design:

Laboratory size	=	12' x 14' x 10'	(1,680 ft ³).
5 foot fume hood	=	250 CFM min*	1,000 CFM max*
Flow offset	=	100 - 500 CFM*	
Ventilation setpoint	=	280 CFM*	(ACPH = 10)
Supply Cooling Volume	=	400 CFM*	
Pressure differential	=	-0.001 in. H ₂ O*	
Temperature setpoint	=	72°F	

* Value supplied by laboratory designer.

Room Pressure Control System:

- (1) Model 8681 Adaptive Offset Control System mounted in the laboratory.
- (2) A through-the-wall pressure sensor mounted between the corridor (referenced space) and laboratory (controlled space).
- (3) Damper, pressure dependent VAV box or venturi valve with actuator assembly mounted in supply air duct(s).
- (4) Damper, pressure dependent VAV box or venturi valve with actuator assembly mounted in exhaust air duct.
- (5) Flow station mounted in supply air duct. (Required for non-venturi valve applications only).
- (6) Flow station mounted in general exhaust air duct. (Required for non-venturi valve applications only).
- (7) Flow station mounted in fume hood exhaust duct. (Required for non-venturi valve applications only).

Temperature Control System:

- (1) Temperature Sensor (1000Ω RTD) mounted in the laboratory.
- (2) Reheat coil mounted in supply air duct(s).

Fume Hood Control System:

- (1) Independent SUREFLOW VAV Face Velocity Control system.

Based on the preceding information, and knowing duct sizes, the following required menu items can be programmed:

MENU ITEM	ITEM VALUE	DESCRIPTION
SUP DCT AREA	1.0 ft ² (12" x 12")	Supply duct area
EXH DCT AREA	0.55 ft ² (10 inch round)	General exhaust duct area
HD1 DCT AREA	0.78 ft ² (12 inch round)	Fume hood duct area
MIN OFFSET	100 CFM	Minimum offset.
MAX OFFSET	500 CFM	Maximum offset.
EXH CONFIG	UNGANGED (Default Value)	
<i>Additional menu items to program for temperature and pressure control.</i>		
VENT MIN SET	280 CFM	10 air changes per hour
COOLING FLOW	400 CFM	Required flow to cool laboratory.
TEMP SETP	72°F	Laboratory temperature setpoint.
SETPOINT	-0.001 in. H ₂ O	Pressure differential setpoint.

Sequence Of Operation

Beginning scenario: Laboratory is maintaining pressure control; -0.001 in. H₂O. Temperature requirement is satisfied. Fume hood sashes are down, total hood exhaust is 250 CFM. Supply air is 280 CFM (maintain ventilation). General exhaust 130 CFM (calculated from below).

$$\begin{array}{r r r r r r r} \text{Fume hood + General exhaust - Offset} & = & \text{Supply air} \\ 250 & + & ? & - & 100 & = & 280 \end{array}$$

The fume hood is opened so that the chemists can load experiments into the hood. The face velocity (100 ft/min) is maintained by modulating the fume hood dampers. The total fume hood flow is now 1,000 CFM.

$$\begin{array}{r r r r r r r} \text{Fume hood + General exhaust - Offset} & = & \text{Supply air} \\ 1,000 & + & 0 & - & 100 & = & 900 \end{array}$$

The supply air volume changes to 900 CFM (1,000 CFM hood exhaust - 100 CFM offset). The general exhaust is closed since no additional exhaust is needed for temperature or ventilation. However, the Digital Interface Module indicates the laboratory is now - 0.0002 in. H₂O (not negative enough). The AOC algorithm slowly changes the offset until pressure control is maintained. In this case the offset changes to 200 CFM, which decreases the supply volume by 100 CFM. The additional offset maintains the pressure differential at - 0.001 in. H₂O (setpoint).

$$\begin{array}{r r r r r r r} \text{Fume hood + General exhaust - Offset} & = & \text{Supply air} \\ 1,000 & + & 0 & - & 200 & = & 800 \end{array}$$

The hood is shut after the experiments are loaded so the initial conditions prevail.

$$\begin{array}{rcccccc} \text{Fume hood} & + & \text{General exhaust} & - & \text{Offset} & = & \text{Supply air} \\ 250 & & 130 & & 100 & & 280 \end{array}$$

An oven is turned on and the laboratory is getting warm. The thermostat sends the AOC a signal to switch to temperature minimum (TEMP MIN SET). This increases the supply air to 400 CFM. The general exhaust air must also increase (damper opens) to maintain flow balance.

$$\begin{array}{rcccccc} \text{Fume hood} & + & \text{General exhaust} & - & \text{Offset} & = & \text{Supply air} \\ 250 & & 250 & & 100 & & 400 \end{array}$$

The control loop continuously keeps the room balance, room pressure, and temperature control satisfied.

Checkout

The AOC controller should have the individual components checked prior to attempting control of the laboratory. The checkout procedure outlined below confirms all hardware is performing correctly. The checkout procedure is not difficult and catches any hardware problems. The steps are as follows:

Confirm wiring is correct.

The most common problem with installed hardware equipment is incorrect wiring. This problem usually exists on initial installation, or when modifications to the system take place. The wiring should be very closely checked to verify it exactly matches the wiring diagram. Polarity must be observed for system to operate correctly. The TSI provided cables are all color coded to ensure proper wiring. A wiring diagram is located in [Appendix B](#) of this manual. Wiring associated with non TSI components should be closely checked for correct installation.

Confirming physical installation is correct

All of the hardware components need to be installed properly. Review the installation instructions and verify components are installed properly at the correct location. This can be easily confirmed when checking the wiring.

Verifying individual components

Verifying all TSI components are operating correctly requires following a simple procedure. The fastest procedure involves first checking the DIM, and then confirming all component parts are functioning.

NOTE: These checks require power to the AOC and all components.

CHECK - DIM

Press **TEST** key to verify Digital Interface Module (DIM) electronics are functioning correctly. At the end of the self test, the display shows SELF TEST - PASSED if DIM electronics are good. If unit displays DATA ERROR at the end of the test, the electronics may be corrupted. Check all software items to determine cause of DATA ERROR.

If SELF TEST - PASSED was displayed proceed to check individual components. Enter **Diagnostics and Flow Check Menu** to check the following:

- Control output - supply (if controlling supply air).
- Control output - exhaust (if controlling exhaust air).
- Control output - reheat (if controlling reheat valve).
- Sensor input (if pressure sensor is installed).
- Sensor status (if pressure sensor installed).
- Temperature input.
- General exhaust flow station.
- Supply flow station.
- Fume hood flow station.

The menu items are explained in detail in the [Menu and Menu Items](#) section of the manual, so their function is not reviewed here. If the AOC system passes each of the checks, the mechanical piece parts are all functioning correctly.

CHECK - Control output - supply

Enter CONTROL SUP menu item in diagnostics menu. A number between 0 and 255 is displayed. Press the ▲/▼ keys until either 0 or 255 shows on the display. Note the position of the supply air control damper. If display reads 0, press the ▲ key until 255 is shown on display. If display reads 255, press ▼ key until 0 is shown on display. Note the position of the supply air damper. The damper should have rotated either 45 or 90 degrees depending on actuator installed.

CHECK - Control output - exhaust

Enter CONTROL EXH menu item in diagnostics menu. A number between 0 and 255 is displayed. Press the ▲/▼ keys until either 0 or 255 shows on the display. Note the position of the general exhaust control damper. If display reads 0, press the ▲ key until 255 is shown on display. If display reads 255, press ▼ key until 0 is shown on display. Note the position of the general exhaust damper. The damper should have rotated either 45 or 90 degrees depending on actuator installed.

CHECK - Control output - temperature

Enter CONTROL TEMP menu item in diagnostics menu. A number between 0 and 255 is displayed. Press the ▲/▼ keys until either 0 or 255 shows on the display. Note the position of the reheat valve. If display reads 0, press the ▲ key until 255 is shown on display. If display reads 255, press ▼ key until 0 is shown on display. Note the position of the reheat valve. The valve should have rotated either 45 or 90 degrees depending on actuator installed.

CHECK - Sensor input

Enter SENSOR INPUT menu item in diagnostics menu. A voltage between 0 and 10 volts DC is displayed. It is not important what the exact voltage is to pass this test. Tape over the pressure sensor (slide pressure sensor door open) and voltage should read approximately 5 volts (zero pressure). Remove tape and blow on sensor. Displayed value should change. If voltage changes, the sensor is functioning correctly. If voltage doesn't change, proceed to CHECK - Sensor status.

CHECK - Sensor status

Enter SENSOR STAT menu item in diagnostics menu. If NORMAL is displayed, the unit passes test. If an error message is displayed, go to diagnostics menu section of the manual, SENSOR STAT menu item for explanation of error message.

CHECK – Temperature sensor input

Enter TEMP INPUT menu item in diagnostics menu. When this item is entered, a temperature, via a 1000Ω platinum RTD, is indicated on the display. The exact temperature displayed is relatively unimportant. It is more important that the temperature is changing which indicates the sensor is working correctly.

CHECK - Flow station

The Flow Check menu lists all the flow stations that can be installed. Check each flow station menu item that has a flow station attached. Enter ___ FLOW IN menu item and the actual flow is displayed. If the flow is correct, no changes need to be made. If flow is incorrect, adjust the corresponding ___ DCT AREA until actual flow matches flow station reading.

If unit passed all checks, the mechanical components are physically working.

Calibration

The calibration section explains how to calibrate and set the elevation for the AOC pressure sensor and how to zero a flow station.

NOTE: The pressure sensor is factory calibrated and normally does not need to be adjusted. However, inaccurate readings may be detected if pressure sensor is not installed correctly, or problems with the sensor exists. Before calibrating, check that the sensor is installed correctly (usually only a problem on initial set up). In addition, go into **DIAGNOSTICS** menu, **SENSOR STAT** item. If **NORMAL** is displayed, calibration can be adjusted. If an error code is displayed, eliminate error code and then verify pressure sensor needs adjustment.

Adjusting the SUREFLOW pressure sensor calibration may be required to eliminate errors due to convection currents, HVAC configuration, or equipment used to make the measurement. TSI recommends always taking the comparison measurement in the exact same location (i.e., under the door, middle of door, edge of door, etc.). A thermal air velocity meter is needed to make the comparison measurement. Normally the velocity is checked at the crack under the doorway, or the door is opened 1" to allow alignment of the air velocity probe making the measurement. If the crack under the door is not large enough, use the 1" open door technique.

All pressure transducer based flow stations and 1-5 VDC linear flow stations must be zeroed upon initial system set up. Linear 0-5 VDC flow stations do not require a zero flow to be established.

Calibrating Pressure Sensor

Enter calibration menu (see [Software Programming](#) if not familiar with key stroke procedure). Access code is turned on so enter access code. All menu items described below are found in **CALIBRATION** menu.

Elevation

The **ELEVATION** item eliminates pressure sensor error due to elevation of building. (See **ELEVATION** item in [Menu and Menu Items](#) section for further information).

Enter the **ELEVATION** menu item. Scroll through the elevation list and select the one closest to the building's elevation.

Press the **SELECT** key to save the data and exit back to the calibration menu.

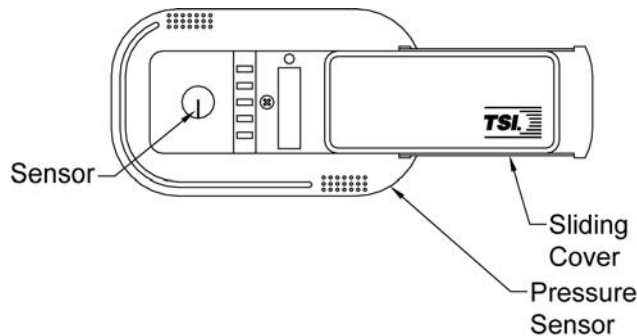

Figure 8: Pressure Sensor Door Slid Open

Sensor span

NOTE: A smoke test and a comparison measurement by an air velocity meter are required to calibrate the pressure sensor. The air velocity meter only gives a velocity reading, so a smoke test must be performed to determine pressure direction.

WARNING: The span can only be adjusted in the same pressure direction. Adjusting span cannot cross zero pressure. Example: If unit displays +0.0001 and actual pressure is -0.0001, do not make any adjustments. Manually change the air balance, close or open dampers, or open door slightly to get both unit and actual pressure to read in same direction (both read positive or negative). This problem can only occur at very low pressures so slightly changing the balance should eliminate the problem.

Perform a smoke test to determine pressure direction.

Select **SENSOR SPAN** item.

Position thermal air velocity meter in door opening to obtain velocity reading. Press ▲/▼ keys until pressure direction (+/-) and sensor span match thermal air velocity meter, and smoke test.

Press **SELECT** key to save sensor span.

Exit menu, calibration is complete.

Flow station pressure transducer zero

NOTE: Not required for linear flow stations with 0 to 5 VDC output.

Pressure based flow station

Disconnect tubing between pressure transducer and flow station.

Enter menu item that corresponds to flow station: Hood flow, Exhaust Flow, or Supply flow.

Select HD1 FLO ZERO or HD2 FLO ZERO to take a fume hood flow station zero.

or

Select EXH FLO ZERO to take a general exhaust flow station zero.

or

Select SUP FLO ZERO to take a supply flow station zero.

Press **SELECT** key. Flow zero procedure, which takes 10 seconds, is automatic.

Press **SELECT** key to save data.

Connect tubing between pressure transducer and flow station.

Linear flow station 1 to 5 VDC output

Remove flow station from duct, or cutoff flow in duct. Flow station must have no flow going past the sensor.

Enter menu item that corresponds to flow station location: Hood flow, Exhaust Flow, or Supply flow.

Select HD1 FLO ZERO or HD2 FLO ZERO to take a fume hood flow station zero.

or

Select EXH FLO ZERO to take a general exhaust flow station zero.

or

Select SUP FLO ZERO to take a supply flow station zero.

Press **SELECT** key. Flow zero procedure, which takes 10 seconds, is automatic.

Press **SELECT** key to save data.

Install flow station back in duct.

2-Point Flow Calibration

Supply and General Exhaust Flow Calibration:

Enter menu that corresponds to flow calibration: Supply Flow, Exhaust Flow.

Select SUP LOW SETP to enter a supply flow low calibration setpoint.

or

Select EXH LOW SETP to enter a general exhaust flow low calibration setpoint.

The DIM displays a value between 0% OPEN and 100% OPEN. Press the ▲ or ▼ keys to adjust the value displayed (and the damper position). Using a voltmeter, read the input voltage from the appropriate pressure transducer. When the voltmeter reading is approximately 20% of the full flow reading (100% OPEN) press the **SELECT** key to save the data.

then

Select SUP HIGH SETP to enter a supply flow low calibration setpoint.

or

Select EXH HIGH SETP to enter a general exhaust flow low calibration setpoint.

The DIM displays a value between 0% OPEN and 100% OPEN. Press the ▲ or ▼ keys to adjust the value displayed (and the damper position). Using a voltmeter, read the input voltage from the appropriate pressure transducer. When the voltmeter reading is approximately 80% of the full flow reading (100% OPEN) press the **SELECT** key to save the data.

then

Select SP LOW CAL to enter a supply flow low calibration value.

or

Select EX LOW CAL to enter a general exhaust flow low calibration value.

The DIM displays two airflow values. Press the ▲ or ▼ keys to adjust the value displayed on the right to match the actual measured airflow, which is obtained with a duct traverse measurement or with a capture hood measurement.

Press **SELECT** key to save data.

then

Select SUP HIGH CAL to enter a supply flow high calibration value.

or

Select EXH HIGH CAL to enter a general exhaust flow high calibration value.

The DIM displays two airflow values. Press the ▲ or ▼ keys to adjust the value displayed on the right to match the actual measured airflow, which is obtained with a duct traverse measurement or with a capture hood measurement.

Press **SELECT** key to save data.

Hood Flow Calibration

Enter HOOD CAL menu. Raise the fume hood sash, of a previously calibrated fume hood, from fully closed to an approximate height of 12". Select the corresponding HD# LOW CAL menu item.

The DIM displays two airflow values. Press the ▲ or ▼ keys to adjust the value displayed on the right to match the actual airflow, which is obtained with a duct traverse measurement or by calculating the volumetric flow. Calculated volumetric flow can be determined by multiplying on the current sash open area by the displayed face velocity.

Press **SELECT** key to save data.

then

Raise the fume hood sash above the low flow calibration, or to its sash stop (approximately 18"). Select the corresponding HD# HIGH CAL menu item.

The DIM displays two airflow values. Press the ▲ or ▼ keys to adjust the value displayed on the right to match the actual airflow, which is obtained with a duct traverse measurement or by calculating the volumetric flow. Calculated volumetric flow can be determined by multiplying on the current sash open area by the displayed face velocity.

Press **SELECT** key to save data.

NOTE: Insert number of flow calibration you are performing.

A low flow calibration **must** be performed before its associated high flow calibration is performed. For example, in a laboratory that has two separate supply flows, SUP LOW CAL must be completed before SUP HIGH CAL.

It is acceptable to complete all low flow calibrations before completing their associated high flow calibrations. To continue with the previous example: HD1 LOW CAL and HD2 LOW CAL could both be completed before completing HD1 HIGH CAL and HD2 HIGH CAL.

Fume hood face velocity calibration must be completed before beginning fume hood flow calibration.

Maintenance and Repair Parts

The Model 8681 SUREFLOW Adaptive Offset Controller requires minimal maintenance. Periodic inspection of system components as well as an occasional pressure sensor cleaning are all that are needed to ensure that the Model 8681 is operating properly.

System Component Inspection

It is recommended that the pressure sensor be periodically inspected for accumulation of contaminants. The frequency of these inspections is dependent upon the quality of the air being drawn across the sensor. Quite simply, if the air is dirty, the sensors require more frequent inspection and cleaning.

Visually inspect the pressure sensor by sliding open the sensor housing door (Figure 9). The air flow orifice should be free of obstructions. The small ceramic coated sensors protruding from the orifice wall should be white and free of accumulated debris.

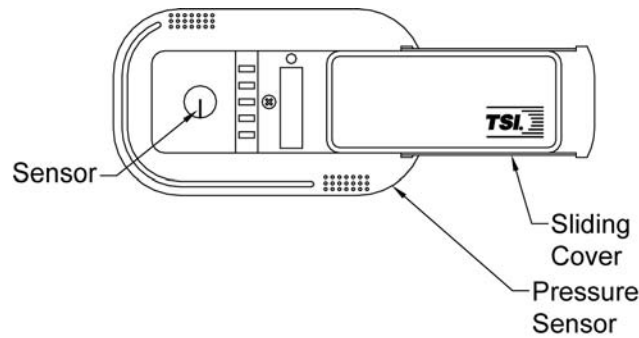

Figure 9: Pressure Sensor Door Slid Open

Periodically inspect the other system components for proper performance and physical signs of excessive wear.

Pressure Sensor Cleaning

Accumulations of dust or dirt can be removed with a dry soft-bristled brush (such as an artist's brush). If necessary, water, alcohol, acetone, or trichlorethane may be used as a solvent to remove other contaminants.

Use extreme care when cleaning the velocity sensors. The ceramic sensor may break if excessive pressure is applied, if sensor is scraped to remove contaminants, or if the cleaning apparatus abruptly impacts the sensor.

WARNING: If you are using a liquid to clean the sensor, turn off power to the Model 8681.

Do **not** use compressed air to clean the velocity sensors.

Do **not** attempt to scrape contaminants from the velocity sensors. The velocity sensors are quite durable; however, scraping may cause mechanical damage and possibly break the sensor. Mechanical damage due to scraping voids the pressure sensor warranty.

Flow Station Inspection / Cleaning

The flow station can be inspected by removing mounting screws and visually examining probe. Pressure based flow stations can be cleaned by blowing compressed air into the low and high pressure taps (flow station does not need to be removed from duct). Linear flow stations (thermal anemometer type) can be cleaned with a dry soft-bristled brush (such as an artist's brush). If necessary, water, alcohol, acetone, or trichlorethane may be used as a solvent to remove other contaminants.

Replacement Parts

All components of the room pressure controller are field replaceable. Contact TSI HVAC Control Products at (800) 874-2811 (U.S. and Canada) or (001 651) 490-2811 (other countries) or your nearest TSI Manufacturer's Representative for replacement part pricing and delivery.

Part Number	Description
800776 or 868128	8681 Digital Interface Module / Adaptive Offset Controller 8681-BAC Digital Interface Module / Adaptive Offset Controller
800326	Pressure Sensor
800248	Sensor Cable
800414	Transformer Cable
800420	Transformer
800199	Controller Output Cable
800360	Electric Actuator

Appendix A

Specifications

Dim and AOC Module

Display

Range	-0.20000 to +0.20000 inches H ₂ O
Accuracy	±10% of reading, ±0.00001 inches H ₂ O
Resolution	5% of reading
Display Update.....	0.5 sec

Inputs

Flow Inputs	See Wiring Information Appendix C for type. 0 to 10 VDC .
Temperature Input.....	1000 Ω Platinum RTD (TC: 385 Ω/100°C)

Outputs

Alarm Contact	SPST (N.O.) Max current 2A Max voltage 220 VDC Maximum power 60 W Contacts close in alarm condition
Supply Control	0 to 10 VDC
Exhaust Control.....	0 to 10 VDC
Reheat Control	0 to 10 VDC or 4 to 20 mA
RS-485	Modbus RTU
BACnet MSTP	Model 8681-BAC only

General

Operating Temperature	32 to 120°F
Input Power	24 VAC, 5 watts max
Dim Dimensions.....	4.9 in. x 4.9 in. x 1.35 in.
Dim Weight.....	0.7 lb.

Pressure Sensor

Temperature Compensation Range	55 to 95°F
Power Dissipation	0.16 watts at 0 inches H ₂ O, 0.20 watts at 0.00088 inches H ₂ O
Dimensions (DxH)	5.58 in. x 3.34 in. x 1.94 in.
Weight.....	0.2 lb.

Damper/Actuator

Types of Actuator.....	Electric
Input Power	Electric: 24 VAC, 7.5 watts max.
Control Signal Input	0 volts damper closed
Time for 90° Rotation	Electric: 1.5 seconds

Appendix B

Network Communications

Network communications are available on the Model 8681 and Model 8681-BAC. The Model 8681 can communicate with a building management system through Modbus protocol. The Model 8681-BAC can communicate with a building management system through BACnet MSTP protocol. Please refer to the appropriate section below for more detailed information.

Modbus Communications

Modbus communications are installed in the Model 8681 adaptive offset room pressure controllers. This document provides the technical information needed to communicate between the host DDC system and the Model 8681 units. This document assumes the programmer is familiar with Modbus protocol. Further technical assistance is available from TSI if your question is related to TSI interfacing to a DDC system. If you need further information regarding Modbus programming in general, please contact:

Modicon Incorporated (a division of Schneider-Electric)
One High Street
North Andover, MA 01845
Phone (800) 468-5342

The Modbus protocol utilizes the RTU format for data transfer and Error Checking. Check the Modicon Modbus Protocol Reference Guide (PI-Mbus-300) for more information on CRC generation and message structures.

The messages are sent at 9600 baud with 1 start bit, 8 data bits, and 2 stop bits. Do not use the parity bit. The system is set up as a master slave network. The TSI units act as slaves and respond to messages when their correct address is polled.

Blocks of data can be written or read from each device. Using a block format speeds up the time for the data transfer. The size of the blocks is limited to 20 bytes. This means the maximum message length that can be transferred is 20 bytes. The typical response time of the device is around 0.05 seconds with a maximum of 0.1 seconds.

Unique to TSI

The list of variable addresses shown below skips some numbers in the sequence due to internal Model 8681 functions. This information is not useful to the DDC system and is therefore deleted. Skipping numbers in the sequence will not cause any communication problems.

All variables are outputted in English units: ft/min, CFM, or inches H₂O. The room pressure control setpoints and alarms are stored in ft/min. The DDC system must convert the value to inches of water if that is desired. The equation is given below.

$$\text{Pressure in inches H}_2\text{O} = 6.2 \times 10^{-8} \times (\text{Velocity in ft/min} / .836)^2$$

RAM Variables

RAM variables use the Modbus command **04 Read Input Registers**. RAM variables are read only variables that correspond to what is shown on the Digital Interface Module (DIM) display. TSI offers a number of different models, so if a feature is not available on a unit, the variable is set to 0.

8681 RAM Variable List

Variable Name	Variable Address	Information Provided to Master System	Integer DDC System Receives
Room Velocity	0	Velocity of room pressure	Displayed in ft/min.
Room Pressure	1	Room pressure	Displayed in inches H ₂ O. Host DDC system must divide value by 100,000 to report pressure correctly.
Space Temperature	2	Current temperature value	Displayed in °F.
Supply Flow Rate	3	Flow (CFM) measured by the supply duct flow station	Displayed in CFM.
General Exhaust Flow Rate	4	Flow measured by flow station connected to general exhaust input	Displayed in CFM.
Hood #1 Flow Rate	5	Flow measured by flow station connected to hood input #1	Displayed in CFM.
Hood #2 Flow Rate	6	Flow measured by flow station connected to hood input #2	Displayed in CFM.
Total Exhaust Flow Rate	7	Total exhaust out of laboratory	Displayed in CFM.
Supply Flow Setpoint	8	Current supply setpoint	Displayed in CFM.
Minimum Supply Flow Setpoint	9	Minimum flow setpoint for ventilation.	Displayed in CFM.
General Exhaust Flow Setpoint	10	Current general exhaust setpoint	Displayed in CFM.
Current Offset Value	11	Current offset value	Displayed in CFM.
Status Index	12	Status of SUREFLOW device	0 Normal 1 Alarm = Low Pressure 2 Alarm = High Pressure 3 Alarm = Max Exhaust 4 Alarm = Min Supply 5 Data Error 6 Emergency Mode
Supply % Open	16	Current supply damper position	0 to 100% is displayed
Exhaust % Open	17	Current exhaust damper position	0 to 100% is displayed
Temperature % Open	18	Current temperature control valve position	0 to 100% is displayed
Current Temperature Setpoint	19	Current temperature control setpoint	Displayed in °F.

EXAMPLE of **04 Read Input Registers** function format.
 This example read variable addresses 0 and 1 (Velocity and Pressure from 8681).

QUERY		RESPONSE	
Field Name	(Hex)	Field Name	(Hex)
Slave Address	01	Slave Address	01
Function	04	Function	04
Starting Address Hi	00	Byte Count	04
Starting Address Lo	00	Data Hi Addr0	00
No. Of Points Hi	00	Data Lo Addr0	64 (100 ft/min)
No. Of Points Lo	02	Data Hi Addr1	00
Error Check (CRC)	--	Data Lo Addr1	59 (.00089 "H ₂ O)
		Error Check (CRC)	--

XRAM Variables

These variables can be read using Modbus command **03 Read Holding Registers**. They can be written to using Modbus command **16 Preset Multiple Regs**. Many of these variables are the same “menu items” that are configured from the SUREFLOW keypad. The calibration and control items are not accessible from the DDC system. This is for safety reasons, since each room is individually setup for maximum performance. TSI offers a number of different models, so if a feature is not available on a unit, the variable is set to 0.

8681 XRAM Variable List

Variable Name	Variable Address	Input Provided to Master System	Integer DDC System Receives
Software Version (read only)	0	Current software version	1.00 = 100
Control Device (read only)	1	SUREFLOW Model	6 = 8681
Emergency Mode*	2	Emergency Mode Control	0 Leave emergency mode 1 Enter emergency mode Value returns a 2 when read
Occupancy Mode	3	Occupancy mode device is in	0 Occupied 1 Unoccupied
Pressure Setpoint	4	Pressure control setpoint	Displayed in feet per minute.
Ventilation Minimum Supply Flow Setpoint	5	Minimum supply flow control setpoint in normal mode	Displayed in CFM.
Cooling Flow Setpoint	6	Minimum supply flow control setpoint in temperature mode	Displayed in CFM.
Unoccupied Minimum Supply Flow Setpoint	7	Minimum supply flow control setpoint in unoccupied mode	Displayed in CFM.
Maximum Supply Flow Setpoint	8	Maximum supply flow control setpoint	Displayed in CFM.
Minimum Exhaust Flow Setpoint	9	Minimum exhaust flow control setpoint	Displayed in CFM.
Occupied Temperature Setpoint	10	Occupied Mode Temperature setpoint	Displayed in °F.
Minimum Offset	11	Minimum offset setpoint	Displayed in CFM.
Maximum Offset	12	Maximum offset setpoint	Displayed in CFM.
Low Alarm Setpoint	13	Low pressure alarm setpoint	Displayed in feet per minute.
High Alarm Setpoint	14	High pressure alarm setpoint	Displayed in feet per minute.

8681 XRAM Variable List (continued)

Variable Name	Variable Address	Input Provided to Master System	Integer DDC System Receives
Minimum Supply Alarm	15	Minimum supply flow alarm	Displayed in CFM.
Maximum Exhaust Alarm	16	Maximum general exhaust alarm	Displayed in CFM.
Units	22	Current pressure units displayed	0 Feet per minute 1 meters per second 2 inches of H ₂ O 3 Pascal
Unoccupied Temperature Setpoint	75	Unoccupied Mode Temperature setpoint	Displayed in °F.

EXAMPLE of **16 (10 Hex) Preset Multiple Regs** function format:
This example changes the setpoint to 100 ft/min.

QUERY		RESPONSE	
Field Name	(Hex)	Field Name	(Hex)
Slave Address	01	Slave Address	01
Function	10	Function	10
Starting Address Hi	00	Starting Address Hi	00
Starting Address Lo	04	Starting Address Lo	04
No. Of Registers Hi	00	No. of Registers Hi	00
No. Of Registers Lo	01	No. of Registers Lo	01
Data Value (High)	00	Error Check (CRC)	--
Data Value (Low)	64		
Error Check (CRC)	--		

Example of **03 Read Holding Registers** function format:
This example reads the minimum ventilation setpoint and the minimum temperature setpoint.

QUERY		RESPONSE	
Field Name	(Hex)	Field Name	(Hex)
Slave Address	01	Slave Address	01
Function	03	Function	03
Starting Address Hi	00	Byte Count	04
Starting Address Lo	05	Data Hi	03
No. Of Registers Hi	00	Data Lo	8E (1000 CFM)
No. Of Registers Lo	02	Data Hi	04
Error Check (CRC)	--	Data Lo	B0 (1200 CFM)
		Error Check (CRC)	

8681 BACnet MS/TP Protocol Implementation Conformance Statement

Date: April 27, 2007

Vendor Name: TSI Inc.

Product Name: SUREFLOW Adaptive Offset Controller

Product Model Number: 8681-BAC

Applications Software Version: 1.0

Firmware Revision: 1.0

BACnet Protocol Revision: 2

Product Description:

TSI SUREFLOW™ Room Pressure Controls are designed to maintain more exhaust from a laboratory than is supplied to it. This negative air balance helps ensure that chemical vapors cannot diffuse outside the laboratory, complying with requirements in NFPA 45-2000 and ANSI Z9.5-2003. The SUREFLOW Model 8681 also controls the temperature of the laboratory space by modulating reheat and the supply air volume. Optionally, a room pressure sensor can be connected to the SUREFLOW Model 8681 controller to correct long-term changes in the building dynamics. This model controller is capable of acting as a stand-alone device or as part of a building automation system via BACnet MS/TP protocol.

BACnet Standardized Device Profile (Annex L):

- BACnet Operator Workstation (B-OWS)
- BACnet Building Controller (B-BC)
- BACnet Advanced Application Controller (B-AAC)
- BACnet Application Specific Controller (B-ASC)
- BACnet Smart Sensor (B-SS)
- BACnet Smart Actuator (B-SA)

List all BACnet Interoperability Building Blocks Supported (Annex K):

DS-RP-B	DM-DDB-B
DS-WP-B	DM-DOB-B
DS-RPM-B	DM-DCC-B

Segmentation Capability:

Segmented requests not supported
Segmented responses not supported

Standard Object Types Supported:

	Dynamically Createable	Dynamically Deletable	Optional Properties Supported	Writable Properties (Data Type)
Analog Input	No	No		
Analog Value	No	No		Present_Value (Real)
Binary Input	No	No	Active_Text, Inactive_Text	
Binary Value	No	No	Active_Text, Inactive_Text	Present_Value (Enumerated)
Multi-state Input	No	No	State_Text	
Multi-state Value	No	No	State_Text	Present_Value (Unsigned Int)
Device Object	No	No		Object Name (Char String) Max Master (Unsigned Int)

Data Link Layer Options:

- BACnet IP, (Annex J)
- BACnet IP, (Annex J), Foreign Device
- ISO 8802-3, Ethernet (Clause 7)
- ANSI/ATA 878.1, 2.5 Mb. ARCNET (Clause 8)
- ANSI/ATA 878.1, RS-485 ARCNET (Clause 8), baud rate(s)
- MS/TP master (Clause 9), baud rate(s): 76.8k 38.4k, 19.2k, 9600 bps
- MS/TP slave (Clause 9), baud rate(s):
- Point-To-Point, EIA 232 (Clause 10), baud rate(s):
- Point-To-Point, modem, (Clause 10), baud rate(s):
- LonTalk, (Clause 11), medium:
- Other:

Device Address Binding:

Is static device binding supported? (This is currently necessary for two-way communication with MS/TP slaves and certain other devices.) Yes No

Networking Options:

- Router, Clause 6 - List all routing configurations, e.g., ARCNET-Ethernet, Ethernet-MS/TP, etc.
- Annex H, BACnet Tunneling Router over IP
- BACnet/IP Broadcast Management Device (BBMD)

Character Sets Supported:

Indicating support for multiple character sets does not imply that they can all be supported simultaneously.

- ANSI X3.4
- IBM™/Microsoft™ DBCS
- ISO 8859-1
- ISO 10646 (UCS-2)
- ISO 10646 (UCS-4)
- JIS C 6226

If this product is a communication gateway, describe the types of non-BACnet equipment/networks(s) that the gateway supports:

Not Applicable

Model 8681-BAC BACnet MS/TP Object Set

Object Type	Device Instance	*Units	Description	
Analog Input	1	ft/min, m/s, in. H ₂ O, Pa	Room Pressure	
Analog Input	2	cfm, l/s	Supply Flow Rate	
Analog Input	3	cfm, l/s	Supply Flow Setpoint	
Analog Input	4	cfm, l/s	General Exhaust Flow Rate	
Analog Input	5	cfm, l/s	General Exhaust Flow Setpoint	
Analog Input	6	cfm, l/s	Hood Flow Rate	
Analog Input	7	cfm, l/s	Current Flow Offset	
Analog Input	8	°F, °C	Temperature	
Analog Input	9	% Open	Supply Damper Position	
Analog Input	10	% Open	Exhaust Damper Position	
Analog Input	11	% Open	Reheat Valve Position	
Analog Value	1		MAC Address	1 to 127
Analog Value	2	ft/min, m/s, in. H ₂ O, Pa	Room Pressure Setpoint	-0.19500 to 0.19500 in. H ₂ O
Analog Value	3	ft/min, m/s, in. H ₂ O, Pa	Low Pressure Alarm	-0.19500 to 0.19500 in. H ₂ O
Analog Value	4	ft/min, m/s, in. H ₂ O, Pa	High Pressure Alarm	-0.19500 to 0.19500 in. H ₂ O
Analog Value	5	cfm, l/s	Vent Min Setpoint	0 to 30,000 cfm
Analog Value	6	cfm, l/s	Cooling Flow Setpoint	0 to 30,000 cfm
Analog Value	7	cfm, l/s	Unocc Flow Setpoint	0 to 30,000 cfm
Analog Value	8	cfm, l/s	Max Supply Setpoint	0 to 30,000 cfm
Analog Value	9	cfm, l/s	Min Exhaust Setpoint	0 to 30,000 cfm
Analog Value	10	cfm, l/s	Min Offset	0 to 30,000 cfm
Analog Value	11	cfm, l/s	Max Offset	0 to 30,000 cfm
Analog Value	12	cfm, l/s	Min Supply Alarm	0 to 30,000 cfm
Analog Value	13	cfm, l/s	Max Exhaust Alarm	0 to 30,000 cfm
Analog Value	14	°F, °C	Temperature Setpoint	50 to 85 °F
Analog Value	15	°F, °C	Unocc Temp Setpoint	50 to 85 °F
Binary Value	1		Occ/Unocc Mode	0 Occupied 1 Unoccupied
Multi-State Input	1		Status Index	1 Normal 2 Low Press Alarm 3 High Press Alarm 4 Max Exhaust Alarm 5 Min Supply Alarm 6 Data Error 7 Emergency
Multi-State Value	2		Emergency Mode	1 Exit Emergency Mode 2 Enter Emergency Mode 3 Normal
Multi-State Value	3		Units Value	1 ft/min 2 m/s 3 in. H ₂ O 4 Pa
Device	868001**		TSI8681	

* The units are based on the value of the Units Value object. When the Units Value is set to 1 or 3 the units are in English form. When the Units Value is set to 2 or 4 the units are metric. English is the default value.

** The device instance is 868000, summed with the MAC address of the device.

Appendix C

Wiring Information

Back Panel Wiring

PIN #	Input / Output / Communication	Description
	DIM / AOC	
1, 2	Input	24 VAC to power Digital Interface Module (DIM). NOTE: 24 VAC becomes polarized when connected to DIM.
3, 4	Output	24 VAC power for Pressure Sensor
5, 6	Input	0 to 10 VDC pressure sensor signal
7, 8	Communications	RS-485 communications between DIM and pressure sensor
9, 10	Output	0 to 10 VDC, general exhaust control signal. 10 VDC = open (n.o. damper) - See menu item CONTROL SIG
11, 12	Input	0 to 10 VDC flow station signal - fume exhaust (HD1 FLOW IN).
13, 14	Output	Alarm relay - N.O., closes in low alarm condition. - See menu item ALARM RELAY
15, 16	Communications	RS - 485 communications; AOC to building management system.
17, 18	Output	0 to 10 VDC, supply air control signal. 10 VDC = open (n.o. damper) - See menu item CONTROL SIG
19, 20	Input	0 to 10 VDC flow station signal - General exhaust (EXH FLOW IN) .
21, 22	Input	0 to 10 VDC flow station signal - Supply air (SUP FLOW IN).
23, 24	Input	1000Ω platinum RTD temperature input signal
25, 26	Output	0 to 10 VDC, reheat valve control signal. 10 VDC = open (n.o. damper) - See menu item REHEAT SIG
27, 28	Input	0 to 10 VDC flow station signal - fume exhaust (HD2 FLOW IN). BACnet MSTP communications to building management system.

WARNING: The wiring diagram shows polarity on many pairs of pins: + / -, H / N, A / B. Damage to DIM may occur if polarity is not observed.

NOTE: Terminals 27 & 28 are utilized for BACnet MSTP communications for Model 8681-BAC. The Model 8681-BAC controller cannot accept a second fume hood flow input; and all second fume hood flow menu items will be deleted from the menu structure.

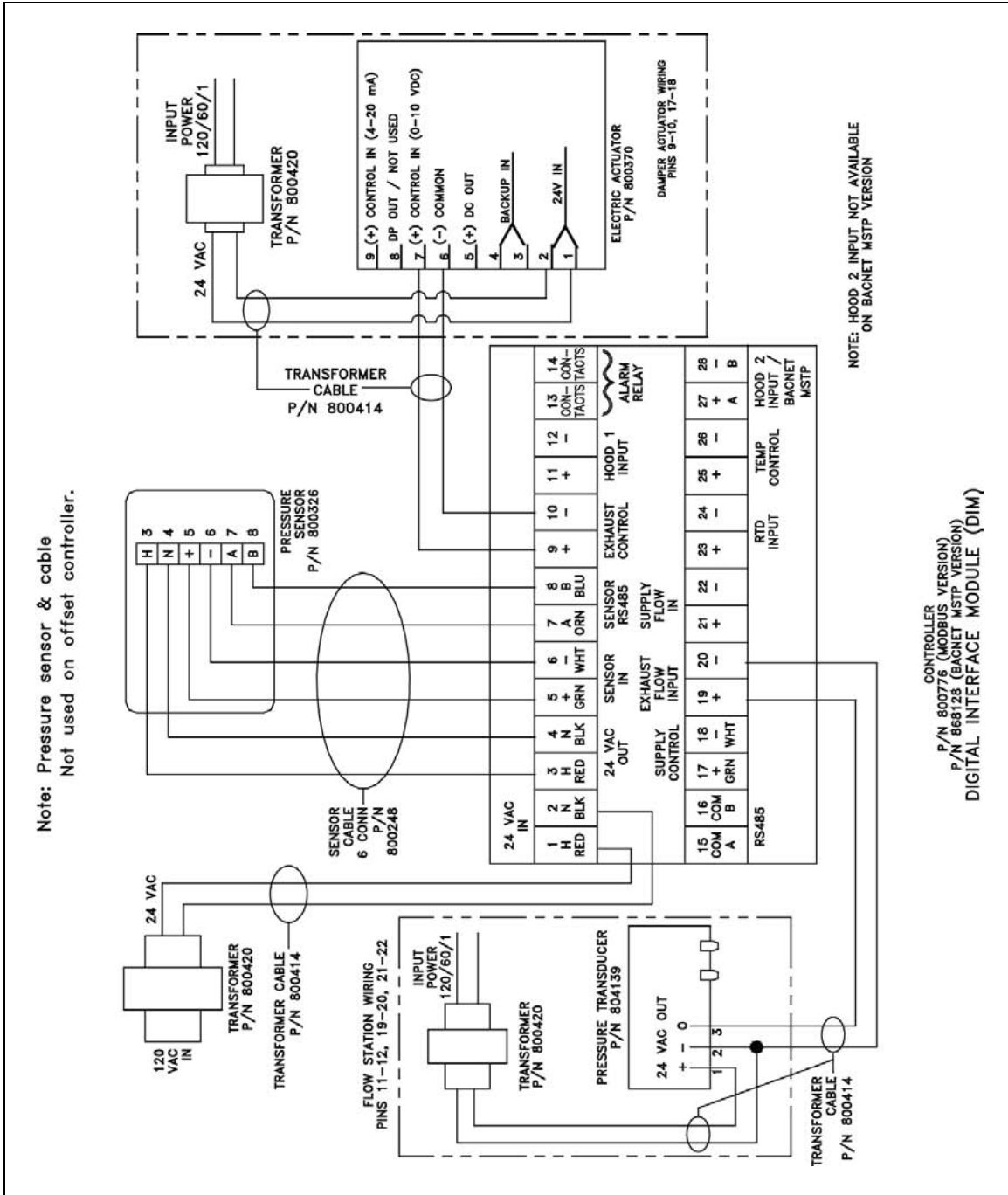

WARNING: Controller must be wired exactly as wire diagram shows. Making modifications to the wiring may severely damage the unit.

Figure 10: Adaptive Offset Wiring Diagram - Damper System with Electric Actuator

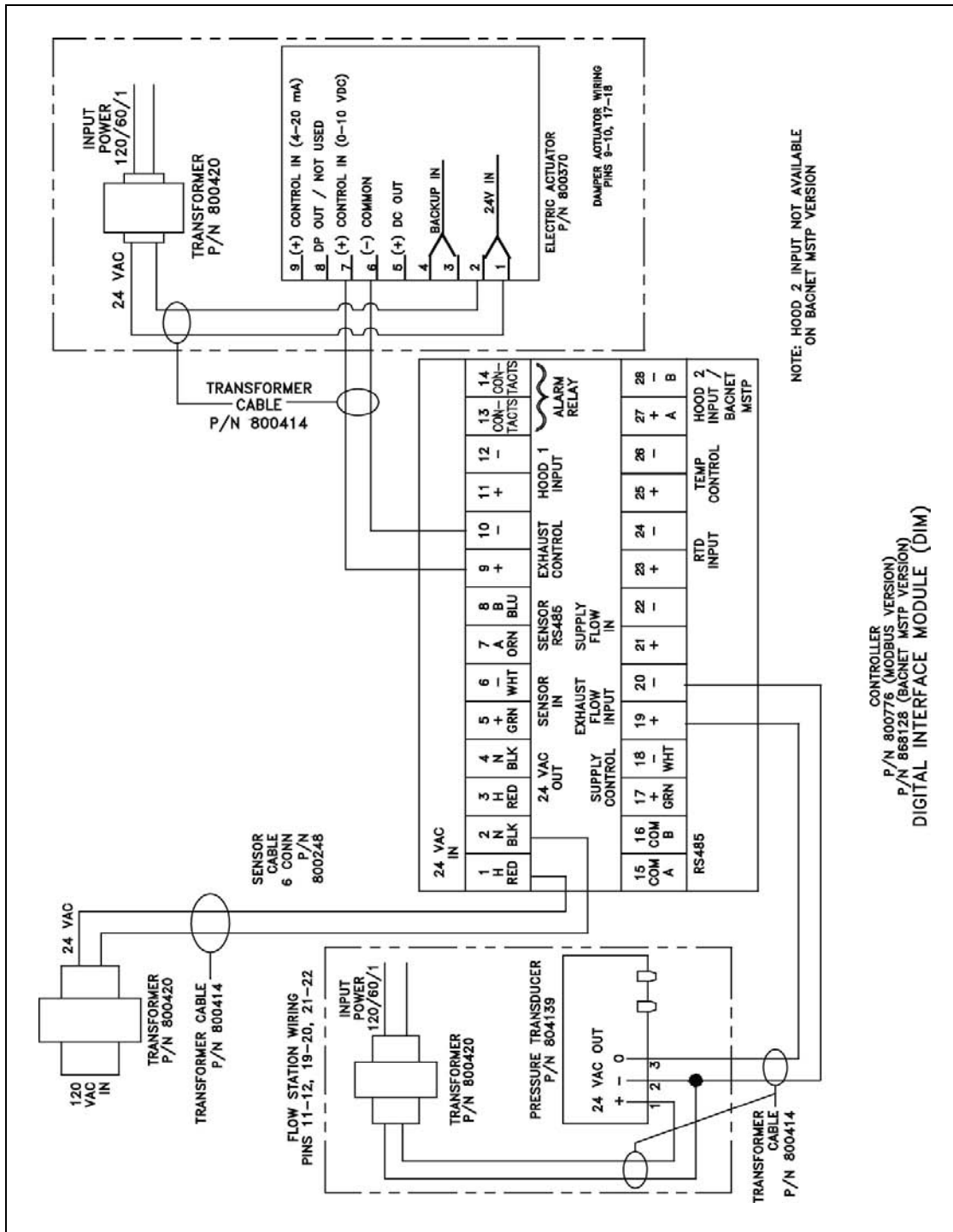

CONTROLLER
P/N 800776 (MODBUS VERSION)
P/N 868128 (BAGNET MSTP VERSION)
DIGITAL INTERFACE MODULE (DIM)

WARNING: Controller must be wired exactly as wire diagram shows. Making modifications to the wiring may severely damage the unit.

Figure 11: Offset (Flow Tracking) Wiring Diagram - Damper System with Electric Actuator

Appendix D

Access Codes

There is one access code for all menus. Each menu can have the access code ON or OFF. IF on the access code must be entered. Pressing the key sequence below allows access to the menu. The access code must be entered within 40 seconds and each key must be pressed within 8 seconds. Incorrect sequence will not allow access to the menu.

<u>Key #</u>	<u>ACCESS CODE</u>
1	Emergency
2	Mute
3	Mute
4	Menu
5	Aux

TSI Incorporated - 500 Cardigan Road, Shoreview, MN 55126-3996 USA

USA	Tel: +1 800 874 2811	E-mail: info@tsi.com	Website: www.tsi.com
UK	Tel: +44 149 4 459200	E-mail: tsiuk@tsi.com	Website: www.tsiinc.co.uk
France	Tel: +33 491 95 21 90	E-mail: tsifrance@tsi.com	Website: www.tsiinc.fr
Germany	Tel: +49 241 523030	E-mail: tsigmbh@tsi.com	Website: www.tsiinc.de
Sweden	Tel: +46 8 595 13230	E-mail: tsiab@tsi.com	Website: www.tsi.se
India	Tel: +91 80 41132470	E-mail: tsi-india@tsi.com	
China	Tel: +86 10 8260 1595	E-mail: tsibeijing@tsi.com	



TRUST. SCIENCE. INNOVATION.

Contact your local TSI Distributor or visit our website www.tsi.com for more detailed specifications.

P/N 1980476 Rev. D

Copyright © 2008 by TSI Incorporated

Printed in U.S.A.