



# Manual Supplement

**Model Number: 8635-ST**

**Product/System Title: Static Pressure Controller**

**Contents of this manual supplement include:**

- 1) Sequence of operation
- 2) Description of new software items
- 3) Deleted software menu items
- 4) Menu structure drawing
- 5) Wiring diagram

---

<b>Project:</b>
<b>Date:</b>
<b>Page 1 of 9</b> <b>Released 2/13/02</b>



# Manual Supplement

## Sequence of Operation

The Model 8635-ST unit is a static pressure controller primarily to be used to control the static pressure in a duct. This controller measures the duct static pressure, and modulates a damper or VFD to obtain a desired pressure setpoint.

---

<b>Project:</b>
<b>Date:</b>
<b>Page 2 of 9</b> <b>Released 2/13/02</b>



# Manual Supplement

## Description of New Software Items

### Menu Item

### Description

#### **SETBACK**

The **SETBACK** item is used to set the static pressure setpoint under setback conditions. This is a second control setpoint, activated by the switch input or digital communications.

#### **SETBACK LOW ALM**

The **SETBACK LOW ALM** item sets a setback or second low pressure alarm set point. A setback low alarm condition is defined as when the duct static pressure falls below the **SETBACK LOW ALM** set point.

This item is enabled when the SWITCH INPUT contacts closure, pins 11 and 12, is closed, or the RS-485 communications send the appropriate command.

#### **SETBACK HIGH AL**

The **SETBACK HIGH AL** item sets a setback or second high pressure alarm set point. A setback low alarm condition is defined as when the duct static pressure rises above the **SETBACK HIGH AL** set point.

This item is enabled when the SWITCH INPUT contacts closure, pins 11 and 12, is closed, or the RS-485 communications send the appropriate command.

#### **MINIMUM SETPOINT**

The **MINIMUM SETPOINT** item is used to set the minimum damper position or VFD output as a percent. This value can range from 0% to 100%, with a default of 0%.

#### **TRANSDUCER OUTPUT**

The **TRANSDUCER OUTPUT** item is used to set the transducer output voltage range. This item can be set at either 0-10V or 0-5V.

#### NOTE:

For transducers with a 2-10V output, the 0-10V setting can be used. Similarly, for transducers with a 1-5V output, the 0-5V setting can be used.

<b>Project:</b>
<b>Date:</b>
<b>Page 3 of 9</b>
<b>Released 2/13/02</b>



# Manual Supplement

## MAX PRESSURE

The **MAX PRESSURE** setting is used to set the upper limit of the pressure transducer. This item can be set from 10 Pa to 5000 Pa (0.10 inches of water to 20.00 inches of water). The default value is 500 Pa (2.0 inches of water).

## SENSOR ZERO

The **SENSOR ZERO** item is used to establish the pressure sensor zero pressure point. A zero point needs to be established prior to using the pressure measurement output.

**The 8635-ST needs to have a SENSOR ZERO established on initial setup.** This procedure is detailed in the CALIBRATION section of the model 8635-C manual, under FLOW STATION PRESSURE TRANSDUCER ZERO

## CONTROL SIG

The **CONTROL SIG** item displays the current control output signal as a number between 0 and 255. To test the control output, press the / keys until either 0 or 255 shows on the display. Note the position of the static pressure control damper. If display reads 0, press the key until 255 is shown on the display. If the display reads 255, press the key until 0 is shown on the display. The damper should have changed from the full open to the full closed position, or from the full closed to the full open position. If not, see hardware section *Control system is not controlling* in the model 8635-C manual.

<b>Project:</b>	
<b>Date:</b>	
<b>Page 4 of 9</b>	<b>Released 2/13/02</b>



# Manual Supplement

## Deleted Software Menu Items

The following items have been replaced or eliminated in the 8635-ST:

<b>SETPOINTS MENU</b>	REM SETPOINT VENT MIN SET TEMP MIN SET TEMP LOW TEMP HIGH
<b>ALARM MENU</b>	REM LOW ALM REM HIGH ALM MIN SUP ALM DOOR DELAY
<b>CONFIGURE MENU</b>	EXH DUCT AREA SUP DUCT AREA FLO STA TYPE TOP VELOCITY ROOM VOLUME
<b>CALIBRATION MENU</b>	SENSOR SPAN EXH FLO ZERO SUP FLO ZERO ELEVATION
<b>DIAGNOSTICS MENU</b>	CONTROL SUP CONTROL EXH SENSOR INPUT EXH FLOW IN SUP FLOW IN TEMP INPUT

<b>Project:</b>
<b>Date:</b>
<b>Page 5 of 9</b> <b>Released 2/13/02</b>



# Manual Supplement

## Menu Structure

### SETPOINTS

SETPOINT  
SETBACK  
MINIMUM SETP  
ACCESS CODE

### ALARM

LOW ALM  
HIGH ALM  
SETB LOW ALM  
SETB HIGH AL  
ALARM RESET  
AUDIBLE ALM  
ALARM DELAY  
MUTE TIMEOUT  
ACCESS CODE

### CONFIGURE

DISPLAY AVG  
UNITS  
TRANSD. OUTP  
MAX PRESSURE  
ACCESS CODE

### CALIBRATION

SENSOR ZERO  
ACCESS CODE

### CONTROL

SPEED  
SENSITIVITY  
CONTROL SIG  
OUTPUT MODE  
KC VALUE  
TI VALUE  
TD VALUE  
ACCESS CODE

### INTERFACE

NET PROTOCOL  
NET ADDRESS  
ACCESS CODE

### DIAGNOSTICS

CONTROL SIG  
ANALOG OUT  
SENSOR INPUT  
SWITCH INPUT  
LOW ALM REL  
HIGH ALM REL  
ACCESS CODE

Figure 6: Menu Items - Model 8635 - ST Controller

Project:

Date:

Page 6 of 9

Released 2/13/02



# Manual Supplement

## Wiring Diagrams

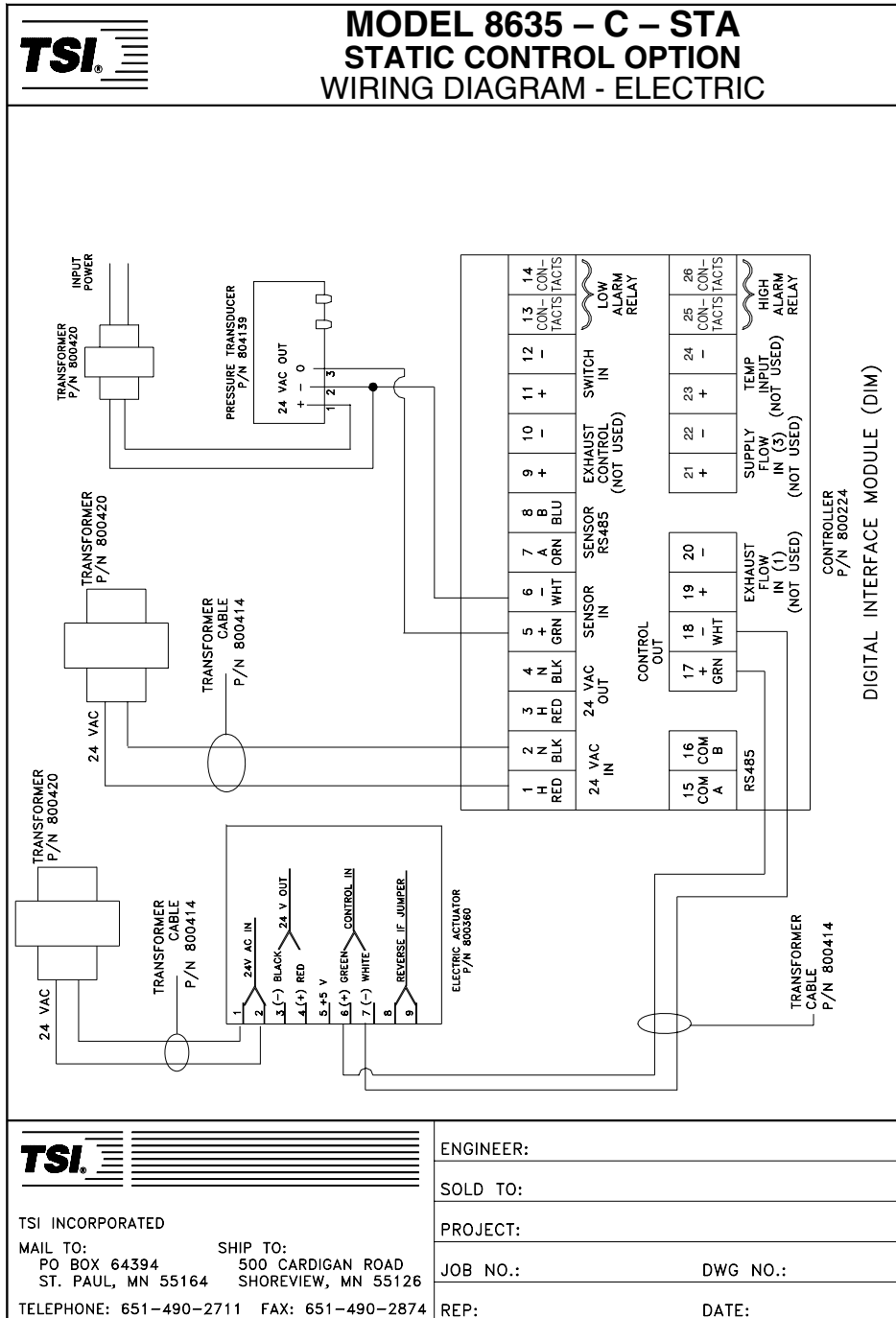

TSI INCORPORATED  
 MAIL TO: PO BOX 64394 ST. PAUL, MN 55164  
 SHIP TO: 500 CARDIGAN ROAD SHOREVIEW, MN 55126  
 TELEPHONE: 651-490-2711 FAX: 651-490-2874

ENGINEER: \_\_\_\_\_

SOLD TO: \_\_\_\_\_

PROJECT: \_\_\_\_\_

JOB NO.: \_\_\_\_\_ DWG NO.: \_\_\_\_\_

REP: \_\_\_\_\_ DATE: \_\_\_\_\_

12/19/01

COPYRIGHT ©,2001 BY TSI INCORPORATED

<b>Project:</b>
<b>Date:</b>
<b>Page 7 of 9</b>
<b>Released 2/13/02</b>



# Manual Supplement

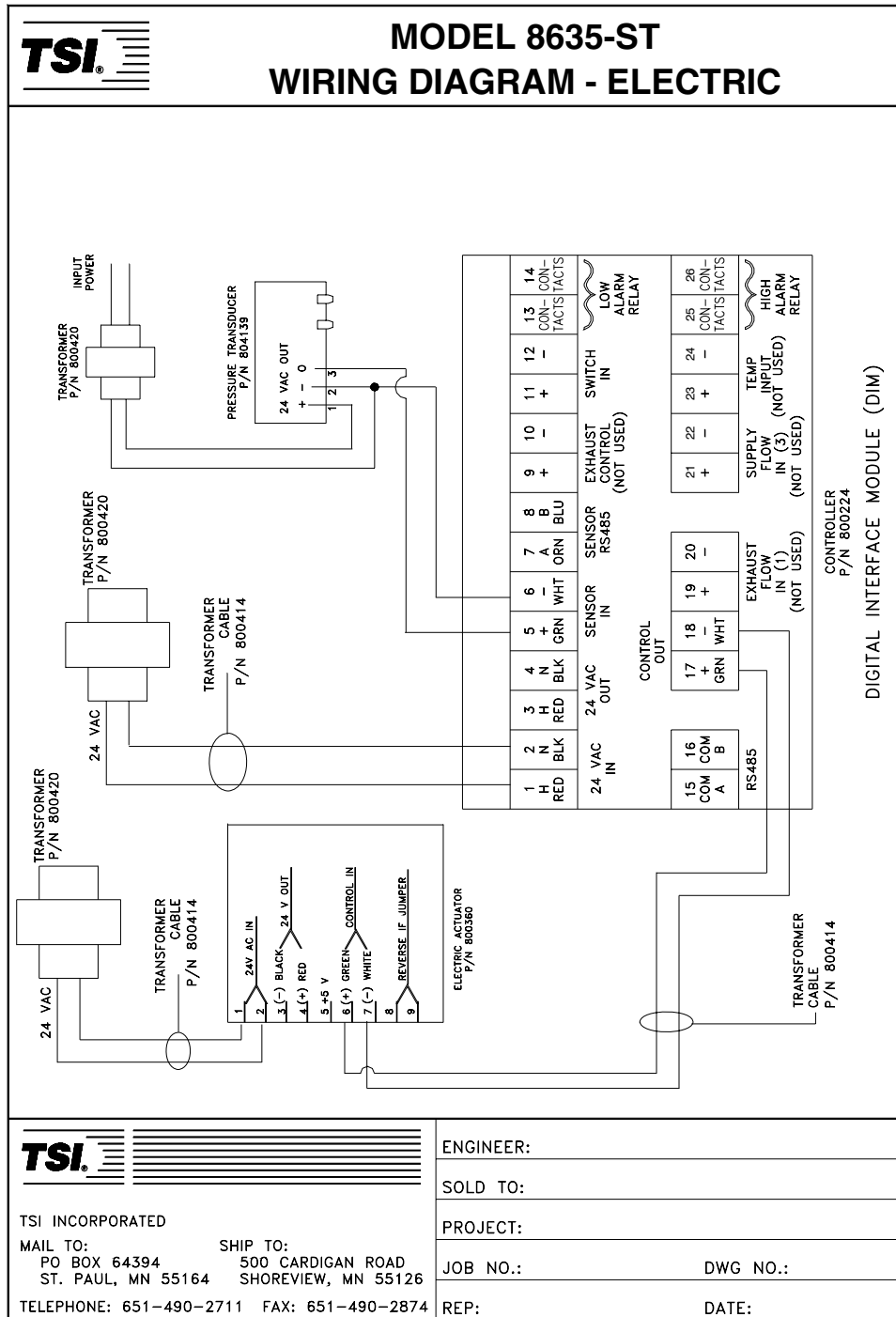

TSI INCORPORATED

MAIL TO: PO BOX 64394 ST. PAUL, MN 55164

SHIP TO: 500 CARDIGAN ROAD SHOREVIEW, MN 55126

TELEPHONE: 651-490-2711 FAX: 651-490-2874

ENGINEER:

SOLD TO:

PROJECT:

JOB NO.: DWG NO.:

REP: DATE:

12/19/01

COPYRIGHT ©,2001 BY TSI INCORPORATED

<b>Project:</b>
<b>Date:</b>
<b>Page 8 of 9</b>
<b>Released 2/13/02</b>



# Manual Supplement

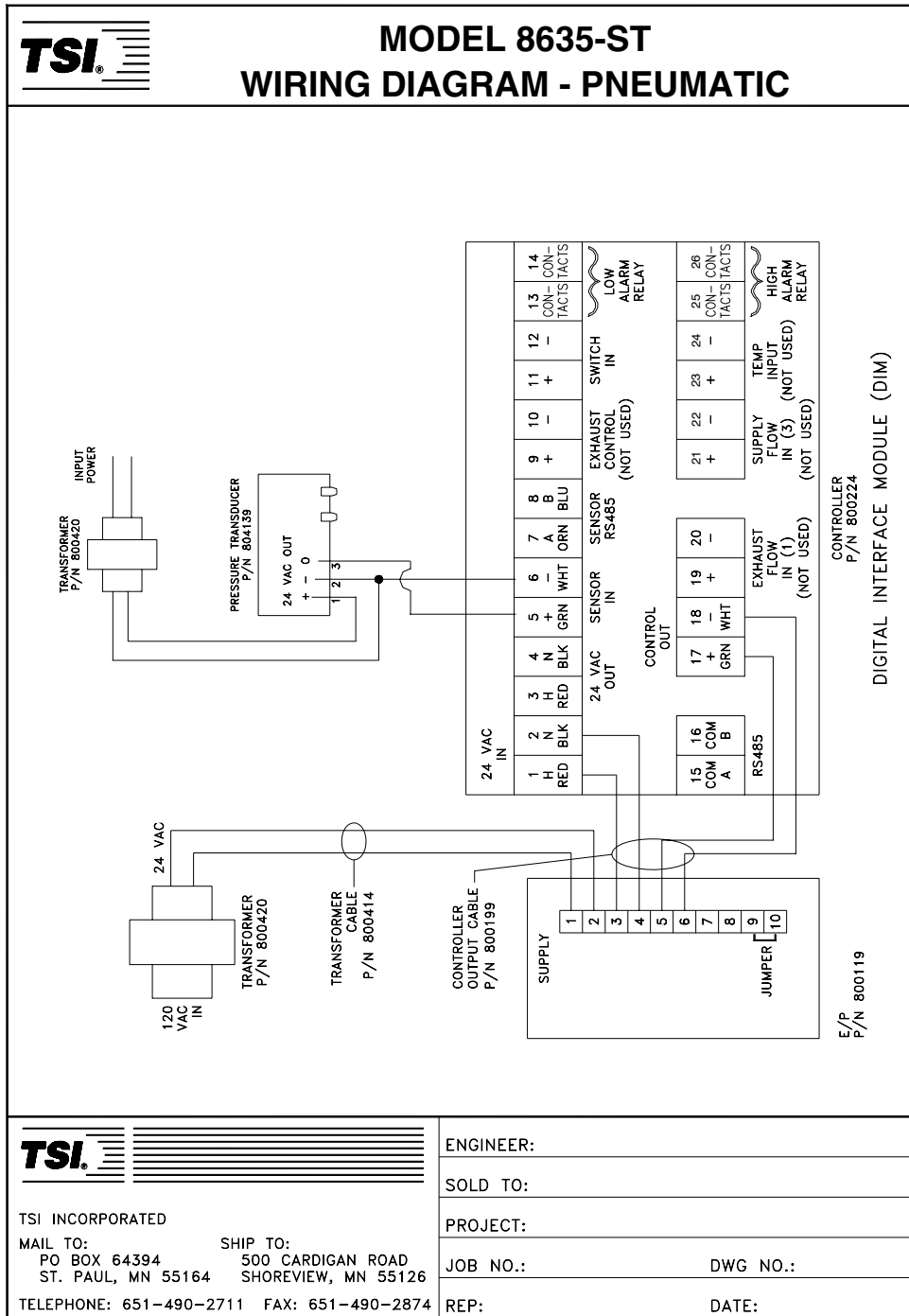

TSI INCORPORATED  
 MAIL TO: PO BOX 64394 ST. PAUL, MN 55164  
 SHIP TO: 500 CARDIGAN ROAD SHOREVIEW, MN 55126  
 TELEPHONE: 651-490-2711 FAX: 651-490-2874

ENGINEER:	
SOLD TO:	
PROJECT:	
JOB NO.:	DWG NO.:
REP:	DATE:

9/10/01

COPYRIGHT ©,2001 BY TSI INCORPORATED

<b>Project:</b>	
<b>Date:</b>	
<b>Page 9 of 9</b>	<b>Released 2/13/02</b>