

TRAVERSING A DUCT TO DETERMINE AVERAGE AIR VELOCITY OR VOLUME

APPLICATION NOTE TSI-106

The following techniques can be used to measure air flow inside ducts, using a velocity probe or pitot-static tube. When using a pitot-static tube, the individual velocities must be calculated for each pressure reading, then averaged together. Averaging pressure with a pitot tube and then converting into velocity will give an incorrect result, especially if many readings are more than $\pm 25\%$ from the average pressure. Remember that for a pitot tube, velocity is proportional to the square root of pressure.

Where to Take the Measurement

In order to make air velocity measurements in a duct, it is best to measure at least 7.5 duct diameters downstream and at least 3 duct diameters upstream from any turns or flow obstructions. It is possible to do a traverse as little as 2 duct diameters downstream and 1 duct diameter upstream from obstructions, but measurement accuracy will be impaired. When measuring rectangular ducts, use this formula to find the equivalent diameter of the duct when calculating how much distance is 7.5 diameters downstream and 3 diameters upstream:

$$\text{Equivalent Diameter} = \text{sq root of } 4HV / \text{Pi}$$

Where:

H = horizontal duct dimension

V = vertical duct dimension

Pi = 3.14

It is also possible to take a single reading to measure air velocity or air volume flow in a duct, measuring in the center of the duct and multiplying the reading by 0.9 to correct for the higher velocity at the center of the duct. If conditions are very good an accuracy of ± 5 or ± 10 percent may be obtained this way. This method is not reliable, however, and should only be used where small duct size or other conditions do not permit a full traverse.

Traversing a Round Duct

Using the log-Tchebycheff method, the duct is divided into concentric circles, each containing equal area. An equal number of readings is taken from each circular area, thus obtaining the best average. Commonly, three concentric circles (6 measuring points per diameter) are used for ducts of 10-inch diameter and smaller. Four or five concentric circles (8 or 10 measuring points per diameter) are used for ducts larger than 10-inch diameter.



The preferred method is to drill 3 holes in the duct at 60° angles from each other as shown in figure 1 below. Three traverses are taken across the duct, averaging the velocities obtained at each measuring point. Then the average velocity is multiplied by the duct area to get the flow rate. (A different method uses 2 holes at 90° from each other, decreasing the number of traverses with the probe by one.)

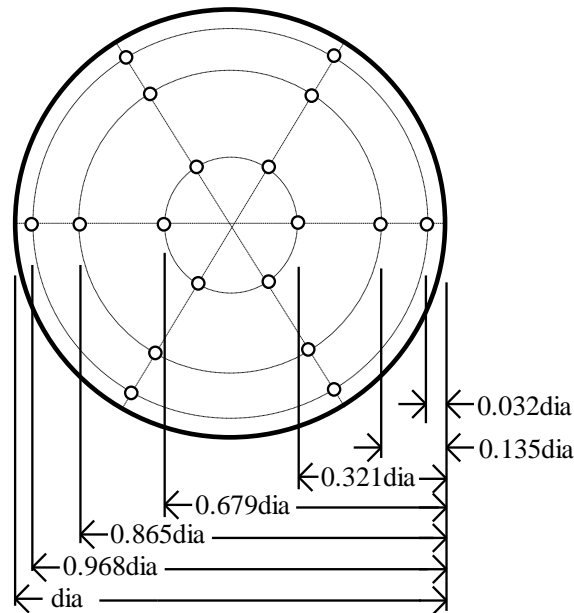

Figure 1: Location of measuring points when traversing a round duct using log-Tchebycheff method

#of Measuring Points Per Diameter	Position Relative to Inner Wall
6	0.032, 0.135, 0.321, 0.679, 0.865, 0.968
8	0.021, 0.117, 0.184, 0.345, 0.655, 0.816, 0.883, 0.979
10	0.019, 0.077, 0.153, 0.217, 0.361, 0.639, 0.783, 0.847, 0.923, 0.981

Before taking the measurement, multiply the numbers in the table times the duct diameter to get insertion depth for the probe. (Don't forget to use the inside dimension of the duct if it is lined with insulation.)

Traversing a Square Duct

Using the log-Tchebycheff method, the duct is divided into rectangular areas, which are further adjusted in size to account for effects of the duct wall on the airflow. A minimum of 25 points must be measured in order to get a good average. The number of data points to be taken along each side of the duct depends on how wide that side of the duct is. For duct sides less than 30 inches, 5 traversal points must be taken along that side. For duct sides of 30 to 36 inches, 6 points must be taken. For duct sides greater than 36 inches, 7 points must be taken. Multiply the numbers in the table times the duct dimension to get insertion depth for the probe.

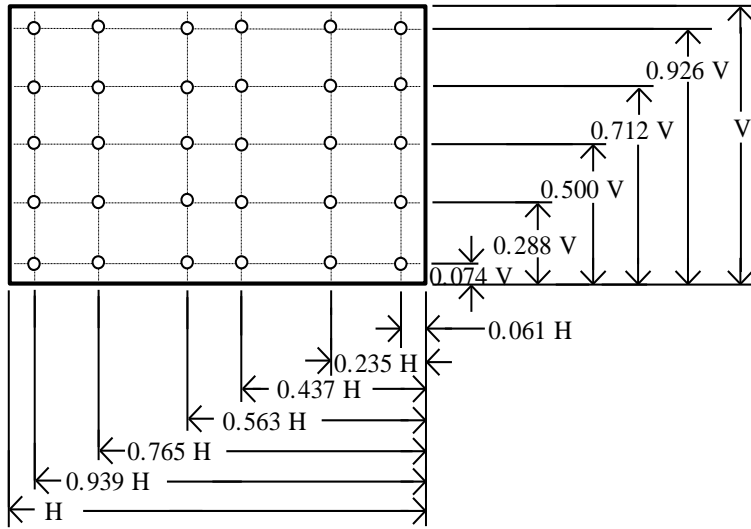

Figure 2: Location of measuring points for traversing a rectangular duct using log-Tchebycheff method

For this duct, a 30-36" horizontal dimension requires 6 points (or 6 traverse lines). For this duct, a vertical dimension less than 30" requires 5 points (or 5 traverse lines).

# of Points or Traverse Lines per Side	Position Relative to Inner Wall
5	0.074, 0.288, 0.500, 0.712, 0.926
6	0.061, 0.235, 0.437, 0.563, 0.765, 0.939
7	0.053, 0.203, 0.366, 0.500, 0.634, 0.797, 0.947

Using the VELOCICALC to Store and Average the Velocity Readings

Select Auto Save as the data logging mode. Select flow rate under the data logging measurements menu. If the thermal anemometer probe is connected the flow readings will utilize the TA probe. If Pitot tube readings are desired, disconnect the TA probe and utilize the pressure ports to measure the Pitot tube. Insert the probe through the duct holes to the depth indicated by the multiplied numbers. At each measurement point, press the **↵ (Enter) Key** to store the reading. When all readings have been taken, review the data in the View Data selection under the Data Logging menu. You can also review each sample in this menu

Notice of Disclaimer

TSI Incorporated has made a good faith effort to provide reliable information regarding the use of the VELOCICALC to conduct a duct traverse. However, we cannot guarantee that the material presented above will guarantee conformance to any particular method or specification, or that this material is free from error. TSI Incorporated recommends purchasing a copy of the duct traverse specification you require from an approved regulatory or professional organization.

For further information, refer to the 2005 ASHRAE Fundamentals Handbook Section 14, or to ASHRAE Standard 111.



UNDERSTANDING, ACCELERATED

TSI Incorporated – Visit our website www.tsi.com for more information.

USA	Tel: +1 800 874 2811	India	Tel: +91 80 67877200
UK	Tel: +44 149 4 459200	China	Tel: +86 10 8251 6588
France	Tel: +33 4 91 11 87 64	Singapore	Tel: +65 6595 6388
Germany	Tel: +49 241 523030		